

Specification: (example)

❑ **55P1513**

- 203mm (8") **heavy-duty cast brass** wallmount pre-rinse faucet
- Integral check stops
- Polished chrome plated finish
- **TUF-TECK[®]** compression structures
- ADA compliant, color-indexed, 76mm (3.0") metal lever blade handles
- 3/8" IPS rigid riser, heavy-duty gooseneck spring, 1118mm (44") stainless steel clad high pressure rubber hose
- 1.6 USGPM @ 60 PSI spray head, self-closing, insulated stop valve, spray head hook.
- *(LESS wall bracket, LESS thin wall installation kit, LESS water/energy saving sprayplate).*

❑ **55P1000**

- 305mm (12") adjustable length Riser wall bracket, thick wall extension pipe, **vibration resistant** compression connector, polished chrome plated finish.



55P1000

❑ **55T1090 (See back page)**

- Add-On Faucet
- Standard 1.5 USGPM (5.7 L/min) flow control Aerator

Engineer/Architect Approval

Model Specified:

Approval:

Date:



55P1513

Approvals:

- CSA certified
 - Complies to ASME A112.18.1
 - Lever Blade Handle
 - ADA Compliant and meets Handicapped Accessibility Standard ASME A117.1 of less than 5 lbs. operating force.
- (Contact Delta Representative for State and/or Local Approvals.)

**Wallmount Faucet
ADJUSTABLE CENTERS**

ADD Suffix "AC" to Product Number

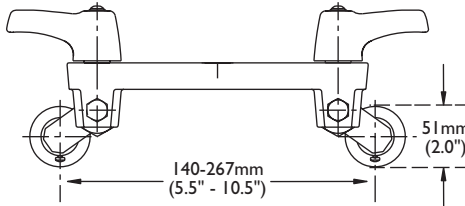

MODEL No. 55T1090

Will add 152mm (6") to overall height

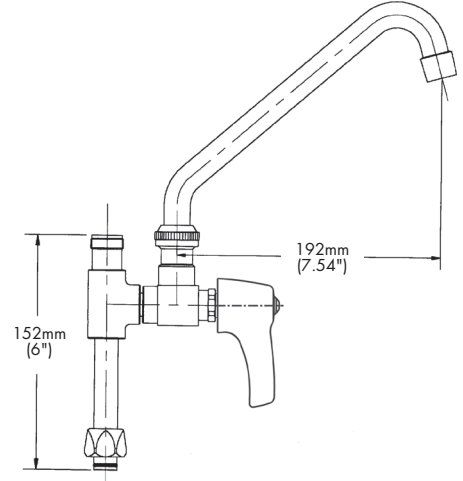

**FOR OPTIONAL
SWING SPOUTS**
 See DSP-S/S for detailed specification
 (Found in the "Add-On Option" section
 when using the printed spec binder)

FLOW RATE vs PRESSURE

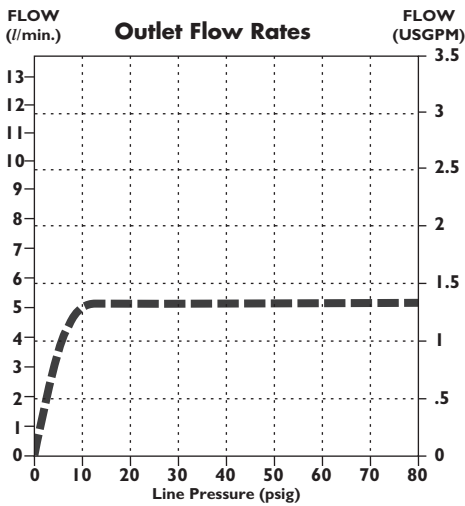

Spout Outlet
 ■ Aerator (55T1090)

Spray Face for 55P1513 (not shown)
 1.6 USGPM @ 60 PSI

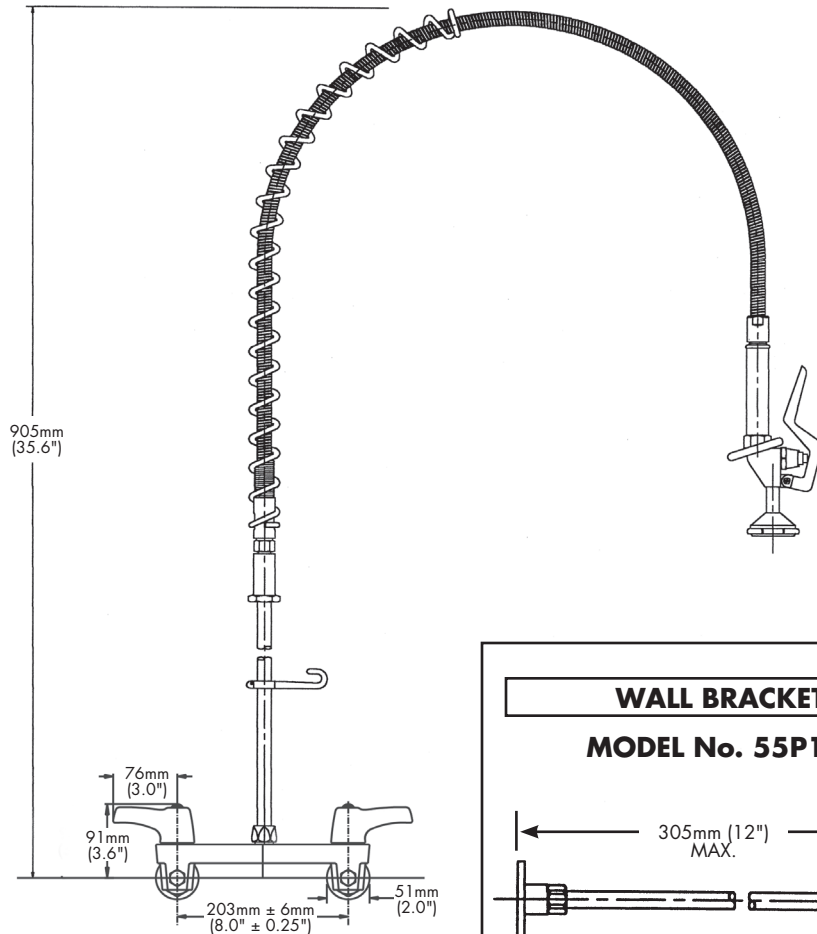

**WALL BRACKET
MODEL No. 55P1000**

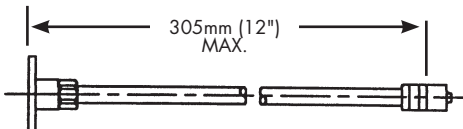
INLETS - 1/2" FIP/MIP

Note: Measurements may vary ± 6mm (0.25")

Refer to www.specselect.com for individual models.

Note: Use this page front and back as a product submittal sheet.