



GERBER

www.gerberonline.com

Maxwell® 1.6 GPF ErgoHeight™ ADA Elongated Toilet

10" Rough-in

Features:

□ MX-21-417

- Vitreous china
- Combination bowl and tank
- 3" Flush valve
- 10" Rough-in
- Round Front bowl
- Dual-fed siphon jet action bowl (no splashing)
- 2" Fully Glazed trapway for effective waste removal
- Color matched metal tank lever
- 6 point tank to bowl connection for tank stability
- Sanitary bead for easy cleaning
- Color matched Bolt caps included
- Toilet seat not included



Technical Information:

Included Components:

- Combination MX-21-417
- Bowl 21-928
- Tank MX-28-995

Fixtures:

Configuration	Two-piece, ADA elongated
Water per Flush	1.6 gpf (6 lpf)
Rough-In	10"
Height	30 1/8"
Width	17 1/4"
Depth	26 3/4"
Trapway	2"
Large Water Surface	8 7/8" x 7 3/8"
Shipping Weight	79 lbs

Accessories:

Soft Close Toilet Seat	99-213
------------------------	--------

Colors/Finishes:

- White
- Other: Refer to Price Book for additional colors/finishes

Warranty:

- Limited lifetime warranty

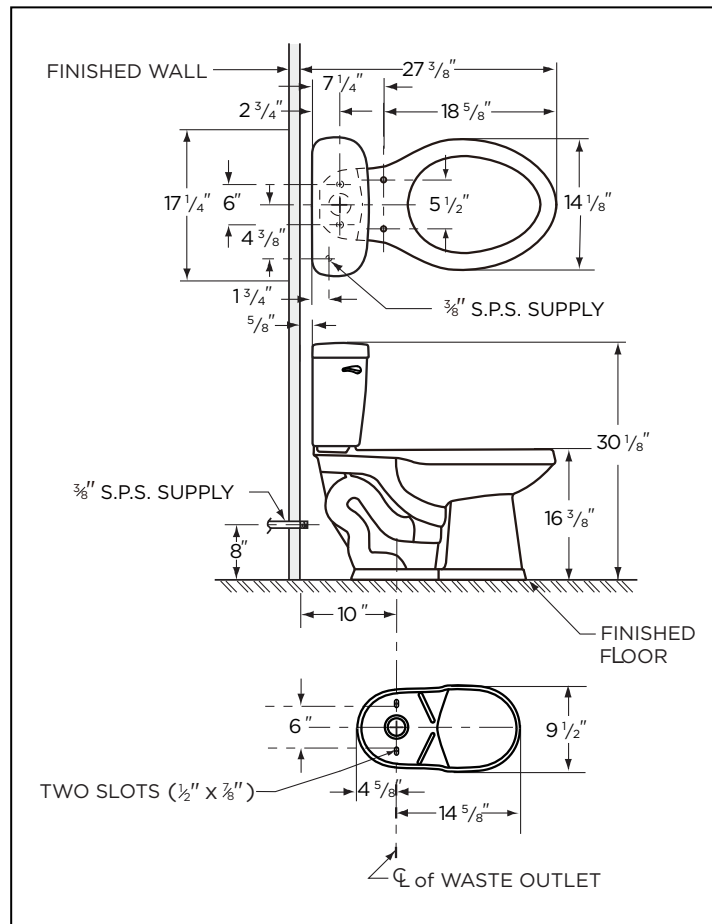

NOTES: All dimensions are in inches. Illustrations may not be drawn to scale.

IMPORTANT:

Dimensions of fixtures are nominal and may vary within the range of tolerances established by ASME standard A 112.19.2 THIS FIXTURE QUALIFIES ACCORDING TO ASME TEST PROCEDURES AS A HIGH EFFICIENCY WATER CLOSET WITH AN AVERAGE CONSUMPTION OF 1.28 gpf (4.8 Lpf) OR LESS.