

JP-PS

Jet Pumps (JP) with Pressure Switch (PS)

Installation and operating instructions

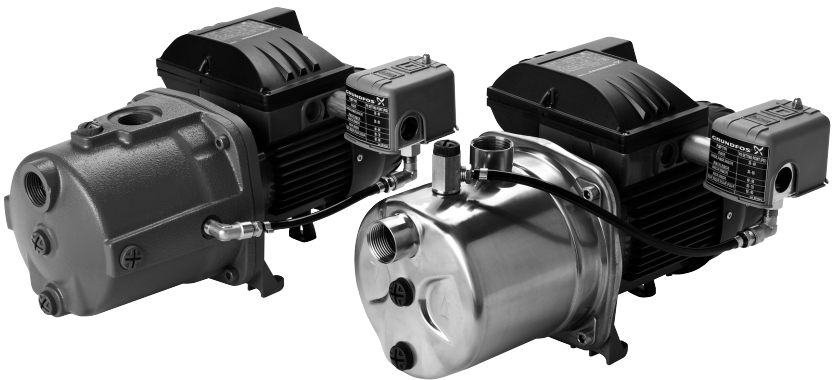

CONTENTS

	Page
1. Limited warranty	2
2. Symbols used in this document	3
3. Introduction	3
3.1 Delivery and handling	3
3.2 Applications	3
3.3 Features and benefits	3
3.4 Identification - type key	5
4. Operating conditions	5
5. Installation	6
5.1 Pre-installation checks	6
5.2 Mechanical installation	6
5.3 Adjusting the pressure switch	7
5.4 Converting from shallow well to deep well operation	7
6. Electrical connection	8
6.1 Voltage switching	8
7. Operation	9
7.1 Startup	9
8. Maintenance and service	9
8.1 Frost protection	9
8.2 Startup after a period of inactivity	9
8.3 Periodic cleaning	9
8.4 Service	10
	10
9.1 Electrical data	11
9.2 Approvals	11
10. Troubleshooting	12
10.1 Motor	12
10.2 Pump	13
10.3 Pressure switch	13
11. Disposal	13

1. Limited warranty

Products manufactured by GRUNDFOS PUMPS CORPORATION (Grundfos) are warranted to the original user only to be free of defects in material and workmanship for a period of 24 months from date of installation, but not more than 30 months from date of manufacture.

Grundfos' liability under this warranty shall be limited to repairing or replacing at Grundfos' option, without charge, F.O.B. Grundfos' factory or authorized service station, any product of Grundfos' manufacture. Grundfos will not be liable for any costs of removal, installation, transportation, or any other charges which may arise in connection with a warranty claim. Products which are sold but not manufactured by Grundfos are subject to the warranty provided by the manufacturer of said products and not by Grundfos' warranty. Grundfos will not be liable for damage or wear to products caused by abnormal operating conditions, accident, abuse, misuse, unauthorized alteration or repair, or if the product was not installed in accordance with Grundfos' printed installation and operating instructions.

To obtain service under this warranty, the defective product must be returned to the distributor or dealer of Grundfos' products from which it was purchased together with proof of purchase and installation date, failure date, and supporting installation data. Unless otherwise provided, the distributor or dealer will contact Grundfos or an authorized service station for instructions.

Any defective product to be returned to Grundfos or a service station must be sent freight prepaid; documentation supporting the warranty claim and/or a Return Material Authorization must be included if so instructed.

GRUNDFOS WILL NOT BE LIABLE FOR ANY INCIDENTAL OR CONSEQUENTIAL DAMAGES, LOSSES, OR EXPENSES ARISING FROM INSTALLATION, USE, OR ANY OTHER CAUSES. THERE ARE NO EXPRESS OR IMPLIED WARRANTIES, INCLUDING MERCHANTABILITY OR FITNESS FOR A PARTICULAR PURPOSE, WHICH EXTEND BEYOND THOSE WARRANTIES DESCRIBED OR REFERRED TO ABOVE.

Some jurisdictions do not allow the exclusion or limitation of incidental or consequential damages and some jurisdictions do not allow limit actions on how long implied warranties may last. Therefore, the above limitations or exclusions may not apply to you. This warranty gives you specific legal rights and you may also have other rights which vary from jurisdiction to jurisdiction.

Warning

Prior to installation, read these installation and operating instructions. Installation and operation must comply with local regulations and accepted codes of good practice.



This booklet should be left with the owner of the pump for future reference and information regarding its operation.

2. Symbols used in this document



Warning

If these safety instructions are not observed, it may result in personal injury!



If these safety instructions are not observed, it may result in malfunction or damage to the equipment!



Notes or instructions that make the job easier and ensure safe operation.

3. Introduction



Warning

The use of this product requires experience with and knowledge of the product. Persons with reduced physical, sensory or mental capabilities must not use this product, unless they are under supervision or have been instructed in the use of the product by a person responsible for their safety.

Children must not use or play with this product.

Grundfos JP-PS jet pumps (JP designates Jet Pump; PS designates Pressure Switch) are of the utmost quality. Combined with proper installation, your Grundfos JP-PS pump will give you many years of reliable service.

To ensure the proper installation of the pump, carefully read the complete manual before attempting to install the pump.



Fig. 1 Grundfos JP-PS jet pumps

TM05 1394 2611

3.1 Delivery and handling

3.1.1 Delivery

Shipment inspection

Examine the pump carefully to make sure no damage has occurred during shipment.

3.1.2 Handling



The pump should remain in the packing until installation.

This Grundfos pump should remain in its shipping carton until it is ready to be installed. The carton is specially designed to protect it from damage.

During unpacking and prior to installation, **make sure that the pump is not dropped or mishandled.**

3.2 Applications

The JP-PS line of self-priming centrifugal jet pumps is designed for shallow well, deep well, and convertible pump applications.

JP-PS pumps provide excellent suction capacity. They are particularly suitable for domestic water supply systems, light agricultural, and industrial water transfer applications. Ideal for small farming applications and gardens.

3.2.1 Pumped liquids

The Grundfos JP-PS line of jet pumps is suitable for pumping clean, non-viscous, non-aggressive, non-explosive liquids, free of solid particles or fibers.

3.3 Features and benefits

3.3.1 Shallow well - cast iron

JP4-47ASA, JP4-54ASA, JP5-61ASA, JP12-51ASA

Single-stage, shallow well self-priming centrifugal pumps. Features:

- Rugged cast iron construction
- end suction, top discharge arrangement
- technopolymer impeller
- built-in ejector complete with clean-out port to clear blockages from nozzle
- convenient priming plug for ease of priming and air elimination
- ceramic-carbon bellows mechanical seal ensures trouble-free operation
- high quality pressure switch.

3.3.2 Convertible - cast iron

(factory set up as shallow well)

JP5-61ASA, JP8-62ASA

Single stage, convertible, self-priming centrifugal pumps. Features:

- Rugged cast iron construction
- end suction, top discharge arrangement
- detachable ejector assembly for deep well applications
- technopolymer impeller
- convenient priming plug for ease of priming and air elimination
- ceramic-carbon bellows mechanical seal ensures trouble-free operation
- high quality pressure switch.

3.3.3 Deep well - cast iron

JP4-47DSA, JP4-54DSA, JP5-61DSA, JP8-62DSA

Single-stage, deep well, self-priming centrifugal pumps. Features:

- Rugged cast iron construction
- end suction, top discharge arrangement
- technopolymer impeller
- separate deep well port for connection to Deep Well Ejector Kit
- convenient priming plug for ease of priming and air elimination
- ceramic-carbon bellows mechanical seal ensures trouble-free operation
- high quality pressure switch.

3.3.4 Shallow well - stainless steel

JP4-47ASI, JP4-54ASI, JP4-61ASI

Single-stage, shallow well self-priming centrifugal pumps constructed of stainless steel. Features:

- Corrosion-resistant stainless steel
- end suction, top discharge arrangement
- technopolymer impeller
- built-in ejector complete with clean-out port to clear blockages from nozzle
- ceramic-carbon bellows mechanical seal ensures trouble-free operation
- high quality pressure switch.

3.3.5 Motors

All Grundfos Jet pump motors are Totally Enclosed and Fan-Cooled (TEFC) for quiet operation and superior protection in harsh environments. Features:

- Induction motor
- closed and cooled with external ventilation
- built-in thermal and current overload protection
- capacitor permanently in circuit
- motor protection IP44
- terminal box protection IP55
- insulation class F.

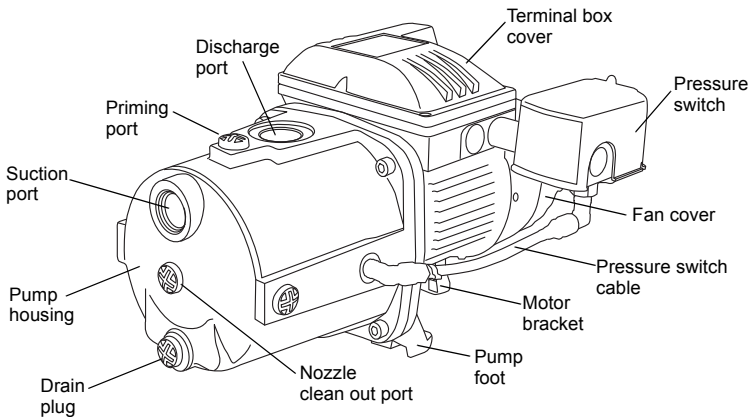

Fig. 2 JP-PS pump cast iron components*

* Stainless steel, convertible, and deep well models differ.

5. Installation

Warning!

All electrical work should be performed by a qualified electrician in accordance with the latest edition of the National Electrical Code, local codes and regulations.

Warning!

Verify that the electrical supply has been switched OFF before making any connections.

The pump should not be connected to the electrical system until it has been properly installed in the piping system.

Note

Reference Square D pressure switch inner cover for electrical schematic.

It is advisable that installation be carried out by skilled personnel in possession of the technical qualifications required by the specific legislation in force.

The term skilled personnel means persons whose training, experience and instruction, as well as their knowledge of the respective standards and requirements for accident prevention and working conditions, have been approved by the person in charge of plant safety, authorizing them to perform all the necessary activities, during which they are able to recognize and avoid all dangers.

Use is allowed only if the electric system is in possession of safety precautions in accordance with the regulations in force in the country where the product is installed.

5.1 Pre-installation checks

5.1.1 Checking motor shaft rotation

Before installing the pump, check that the rotating parts turn freely:

1. Remove the fan cover from its seat in the motor end cover.
2. Insert a screwdriver in the notch on the motor shaft from the ventilation side.
3. If there is a blockage, turn the screwdriver, tapping it gently with a hammer.

See fig. 3.

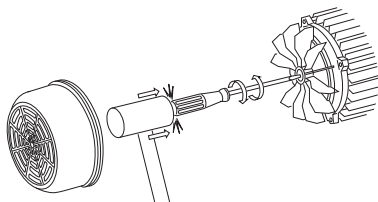

Fig. 3 Correcting blockage of motor shaft rotation

5.2 Mechanical installation

5.2.1 Pump location

Note

Ensure that the maximum ambient temperatures do not exceed +104 °F (+40 °C).

The pump must be located in a well-ventilated place, protected from unfavorable weather conditions and with an environmental temperature not exceeding 104 °F (40 °C).

It is always good practice to place the pump as close as possible to the liquid to be pumped.

5.2.2 Pump position

The pump must be installed only in horizontal position. To prevent movement and vibrations, anchor the pump firmly to a horizontal surface. See fig. 4.

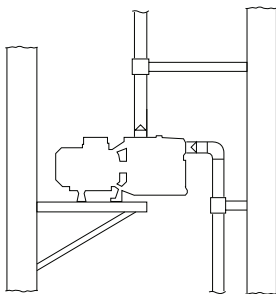

Fig. 4 Anchor pump firmly in horizontal position

5.2.3 Pipework

Note

Never use unnecessary force when connecting the pipes.

Ensure that metal piping does not exert undue strain on the connections, thus preventing deformations or breakages.

The internal diameter of the pipework must never be smaller than the diameter of the suction port.

We recommend to fit a foot valve to the end of the suction pipe.

For suction depths of over 13 ft or with long horizontal stretches, it is advisable to use an intake hose with a diameter larger than that of the intake aperture of the pump.

To prevent the formation of air pockets, the intake hose must slope slightly upward toward the pump. See fig. 5.

If the intake pipe is made of rubber or flexible material, always check that it is of the reinforced type to avoid throttling due to suction.

The pipes must be adequately supported on either side of the pump to avoid straining the connections.

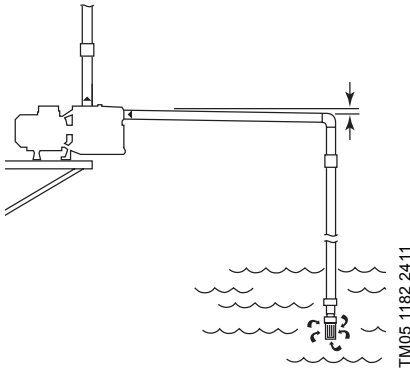

Fig. 5 Intake hose must slope slightly upward

TM05 1182 2411

5.3 Adjusting the pressure switch

1. Establish the minimum desired pressure value (leaving the pump).
2. Set the storage tank preloading pressure to 3 psi less than the minimum pressure level.
3. Turn nut #1 (large nut) clockwise to raise cut-on/off pressures.
4. Turn nut #2 (small nut) clockwise to raise off pressure only.

Note *Reference Square D pressure switch inner cover for additional information.*

5.4 Converting from shallow well to deep well operation

Note *Separate ejector is required to suit specific suction lift needs.*

5.4.1 Conversion from deep well JP5-61DSA - JP8-62DSA to convertible shallow well JP5-61ASA - JP8-62ASA

Screw the nozzle into place on the ejector body and the Venturi tube. Put O-rings into respective places and fasten ejector body to the pump using the two screws. See fig. 6.

5.4.2 Conversion from convertible shallow well JP5-61ASA - JP8-62ASA to deep well JP5-61DSA - JP8-62DSA

Loosen and remove the two screws connecting the ejector body to the pump body. Save the O-rings, the Venturi tube, and the nozzle.

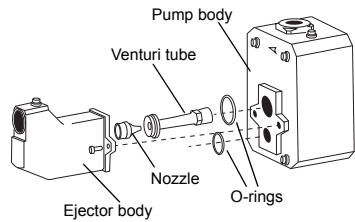

Fig. 6 Convertible ejector kit installation

TM05 1186 2411

6. Electrical connection

Warning!

All electrical work should be performed by a qualified electrician in accordance with the latest edition of the National Electrical Code, local codes and regulations.



Warning!

Ensure that the voltage on the power supply is the same as the voltage shown on the motor nameplate. A faulty motor or winding can cause electrical shock that could be fatal, whether touched directly or conducted through standing water. For this reason, proper grounding of the pump to the power supply's grounding terminal is required for safe installation. The above-ground metal plumbing should be connected to the power supply as a ground as described in Article 250-80 of the National Electrical Code or Section 26-954 of the Canadian Electrical Code.



Note Reference Square D pressure switch inner cover for electrical schematic.

In fixed installations, safety standards require the use of isolating switches with a fuse-carrier base.

Single-phase motors are provided with built-in thermal overload protection with automatic reset, and may be connected directly to the power supply.

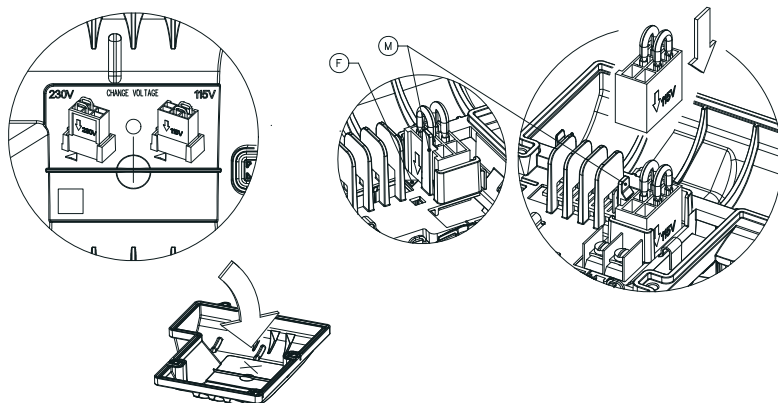

Fig. 7 Voltage switching

6.1 Voltage switching

6.1.1 Fitting the voltage converter

See fig. 7.

1. Check the voltage indicated on the side of the voltage converter.
2. Turn the indicator so that the desired voltage points towards the side with the "M" lock catch.
3. The arrow on the converter next to the required voltage must be aligned with the "F" arrow on the housing.

Warning!

Do not pull the voltage switching plug by the wires. Use only a firm hand grip around the voltage switching plug to avoid damage.



4. Push the converter into position until the reference catch "M" clips in place.

7. Operation

7.1 Startup



Warning!

Do not start the pump until it has been completely filled with liquid. Dry operation causes irreparable damage to the mechanical seal.



The pump should not be started more than 20 times in one hour so as not to subject the motor to excessive thermal shock.

Before starting up, check that the pump is properly primed; see fig. 8.

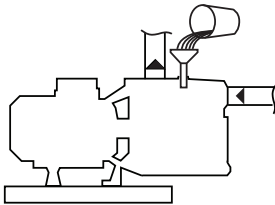

Fig. 8 Pump must be primed before startup

Fill it completely with clean water by means of the hole provided after having removed the filler cap on the pump body. This ensures that the mechanical seal is well lubricated and that the pump immediately starts to work regularly. The filling cap must then be screwed back on carefully.

8. Maintenance and service

8.1 Frost protection



Protect pump from the danger of freezing temperatures which may damage the pump components.

If there is any risk of frost damage, the pump body must be completely emptied through the drain cap (see fig. 9) to prevent possible cracking of the hydraulic components.

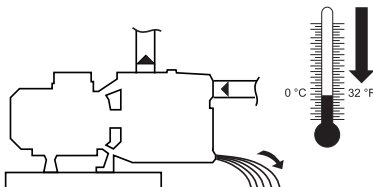

Fig. 9 Draining pump via drain cap

8.2 Startup after a period of inactivity

Even at temperatures above freezing, in the event of prolonged inactivity, it is advisable to completely empty the pump body through the drain cap; see fig. 9.

When starting after long periods of inactivity, the start-up operations listed in section 7. *Operation* must be repeated. The pump must be filled with liquid before it is started up again.

8.3 Periodic cleaning



Warning!

All repairs and maintenance must be carried out only after having disconnected the pump from the power supply.

In normal operation, the pump does not require any specific maintenance. However, it may be necessary to clean the hydraulic parts when a decrease in performance is observed. The pump must not be dismantled except by skilled personnel in possession of the qualifications required by the regulations in force.

Procedure:

1. Remove clean out port plug located below the inlet port; see fig. 10.
2. Insert a thin device (such as an ice pick or bradawl) and gently move it in a "push and pull" motion to dislodge any debris.
3. Reinstall clean out port plug.



During clean out, take care not to break the plastic piece located in the center of the nozzle clean out port.

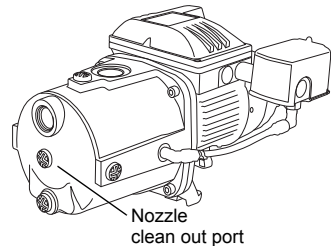

Fig. 10 Locating nozzle clean out port

TM05 1183 2411

TM05 1184 2411

TM051345 2611

8.4 Service

Any modification of the pump not authorized beforehand will relieve the manufacturer of all responsibility and void the pump's warranty.

Note

All the spare parts used in repairs must be original ones and the accessories must be approved by the manufacturer so as to be able to guarantee maximum safety of the machines and systems in which they may be fitted.

If a pump has been used for a liquid that is injurious to health or toxic, the pump will be classified as contaminated.

Note

If Grundfos is requested to service the pump, Grundfos must be contacted with details about the pumped liquid, etc. *before* the pump is returned for service. Otherwise Grundfos can refuse to accept the pump for service. Possible costs of returning the pump are paid by the customer.

However, any application for service (no matter to whom it may be made) must include details about the pumped liquid if the pump has been used for liquids which are injurious to health or toxic.

9. Technical data

Shallow well - cast iron						
Model	JP4-47ASA	JP4-54ASA	JP4-61ASA	JP5-61ASA	JP8-62ASA	JP12-51ASA
Max. flow [gpm (m ³ h)]	21 (4.8)	20 (4.5)	20 (4.5)	23 (5.2)	34 (7.7)	52 (11.8)
Max. pump head [ft (m)]	145 (44.2)	170 (51.2)	200 (61.0)	210 (64.0)	210 (64.0)	170 (51.2)
Max. working pressure [psi (bars)]	116 (8 bars)					
Motor power [hp]	1/2	3/4	1	1 1/2	2	3
Fluid temp range [°F (°C)]	+32 to +95 (0 to +35)					
Max. lift [ft suction lift at sea level]	25					
Max. ambient temp [°F (°C)]	+104 (+40)					
Factory pressure switch setting [psi (bars)]	30/50 (2.1/3.5)	30/50 (2.1/3.5)	40/60 (2.8/4.1)	50/70 (3.5/4.8)	50/80 (3.5/5.5)	50/80 (3.5/5.5)
Storage temp [°F (°C)]	+14 to +104 (-10 to +40)					
Relative humidity	95%					
Max. starts per hour	20					

Shallow well - stainless steel			
Model	JP4-47ASI	JP4-54ASI	JP4-61ASI
Max. flow [gpm (m ³ h)]	21 (4.8)	20 (4.5)	20 (4.5)
Max. pump head [ft (m)]	145 (44.2)	170 (51.2)	200 (61.0)
Max. working pressure [psi (bars)]	116 (8 bars)		
Motor power [hp]	1/2	3/4	1
Fluid temp range [°F (°C)]	+32 to +95 (0 to +35)		
Max. lift [ft suction lift at sea level]	25		
Max. ambient temp [°F (°C)]	+104 (+40)		
Factory pressure switch setting [psi (bars)]	30/50 (2.1/3.5)	30/50 (2.1/3.5)	40/60 (2.8/4.1)
Storage temp range [°F (°C)]	+14 to +104 (-10 to +40)		
Relative humidity	95%		
Max. starts per hour	20		

Deep well - cast iron				
Model	JP4-47DSA	JP4-54DSA	JP5-61DSA	JP8-62DSA
Max. flow [gpm (m ³ h)]	18 (4.1)	18 (4.1)	21 (4.8)	32 (7.3)
Max. pump head [ft (m)]	145 (44.2)	170 (51.2)	195 (59.4)	200 (61.0)
Max. working pressure [psi (bars)]	116 (8 bars)			
Motor power [hp]	1/2	3/4	1 1/2	2
Fluid temp range [°F (°C)]	+32 to +95 (0 to +35)			
Max. lift [ft suction lift at sea level]	50	70	90	90
Max. ambient temp [°F (°C)]	+104 (+40)			
Factory pressure switch setting [psi (bars)]	30/50 (2.1/3.5)	30/50 (2.1/3.5)	50/70 (3.5/4.8)	50/80 (3.5/5.5)
Storage temp range [°F (°C)]	+14 to +104 (-10 to +40)			
Relative humidity	95%			
Max. starts per hour	20			

9.1 Electrical data

Supply voltage:

1 X 115/230V 60Hz

1 X 230V 60Hz

Voltage tolerance +/- 6 %

Electrical data 60 Hz								
Pump model	P2 Power out [hp]	SF	Voltage [V]	In (SFA)		Capacitor rating	Line fuses [amps]	
				1x115V	1x230V		1x115V	1x230V
JP4-47DSA-PS	0.5	1.60	115V/230V	7.09	3.61	50 µF, 250V	8	4
JP4-47ASA-PS	0.5	1.60	115V/230V	8.21	4.22	50 µF, 250V	12	6
JP4-47ASI-PS	0.5	1.60	115V/230V	8.21	4.22	50 µF, 250V	12	6
JP4-54DSA-PS	0.75	1.50	115V/230V	9.20	4.67	50 µF, 250V	12	6
JP4-54ASA-PS	0.75	1.50	115V/230V	10.3	5.25	50 µF, 250V	12	6
JP4-54ASI-PS	0.75	1.50	115V/230V	10.3	5.25	50 µF, 250V	12	6
JP4-61ASA-PS	1	1.40	115V/230V	13.8	7.10	80 µF, 250V	16	8
JP4-61ASI-PS	1	1.40	115V/230V	13.8	7.10	80 µF, 250V	16	8
JP5-61DSA-PS	1.5	1.30	230V	-	7.6	31.5 uF, 450V	-	10
JP5-61ASA-PS	1.5	1.30	230V	-	8.0	31.5 uF, 450V	-	10
JP8-62DSA-PS	2	1.25	230V	-	8.5	40 µF, 450V	-	10
JP8-62ASA-PS	2	1.25	230V	-	11.0	40 µF, 450V	-	12
JP12-51ASA-PS	3	1.15	230V	-	12.0	40 µF, 450V	-	16

9.2 Approvals



File no. 703194

10. Troubleshooting

10.1 Motor

Problem	Possible cause	Possible remedy
1. The motor does not start and makes no noise.	a) Check the electric connections.	If the fault is repeated immediately this means that the motor is short circuiting.
	b) Check that the motor is live.	If the fault is repeated immediately this means that the motor is short circuiting.
	c) Check the protection fuses.	If fuses are burnt out, change them.
	d) Check that the pressure switch is live.	Verify power at the switch terminals.
	e) Ensure that the tank pre-loading pressure is not higher than the minimum value of the pressure switch.	Set the pre-loading pressure 3 psi below the minimum value of the pressure switch.
2. The motor does not start but makes noise.	a) Ensure that the power supply values are the same as the values on the nameplate.	Correct any errors.
	b) Ensure that the connections have been made correctly.	Correct any errors.
	c) Look for possible blockages in the pump or motor.	Remove the blockage.
	d) Check the condition of the capacitor.	Replace the capacitor.
3. The motor turns with difficulty.	a) Check the voltage which may be insufficient.	Correct any errors.
	b) Check whether any moving parts are scraping against fixed parts.	Eliminate the cause of the scraping.
4. The motor does not stop when the demand for water has ceased.	a) Ensure that the value at which the pressure switch is set to stop the motor is not higher than the pressure than the pump can generate (suction + delivery).	Set the pressure switch at a lower pressure.
	b) Check that the pressure switch contacts move freely.	Otherwise change the pressure switch.

10.2 Pump

1. The pump does not deliver.	a) The pump has not been primed correctly.	Review section 7.1 <i>Startup</i> .
	b) The diameter of the intake pipe is insufficient.	Replace the pipe with a larger diameter one.
	c) Blocked foot valve.	Clean the foot valve.
2. The pump does not prime.	a) The intake pipe or the foot valve is taking in air.	Correct the problem and prime again.
	b) The downward slope of the intake pipe favors the formation of air pockets.	Correct the inclination of the intake pipe.
3. The pump supplies insufficient flow.	a) Blocked foot valve.	Clean the foot valve.
	b) The impeller is worn or blocked.	Remove the obstructions or replace the worn parts.
	c) The diameter of the intake pipe is insufficient.	Replace the pipe with one with a larger diameter.
4. The pump vibrates and operates noisily.	a) Check that the pump and the pipes are firmly anchored.	Fix the loose parts more carefully.
	b) There is cavitation in the pump, that is the demand for water is higher than it is able to pump.	Reduce the intake height or check for load losses.
	c) The pump is running above its plate characteristics.	It may be useful to limit the flow at delivery.

10.3 Pressure switch

Problem	Possible cause	Possible remedy
5. The pressure-switch starting and stopping frequently during normal water delivery.	a) Check the setting of the pressure switch to see if it is too low.	Increase the setting values of the pressure switch until the problem is overcome. Do not forget to reset the minimum intervention pressure.
	b) Check that the diaphragm of the expansion chamber (if used) is unbroken.	Otherwise remove the fault.

11. Disposal

Dispose of this product in an environmentally sound way:

1. Use the public or private waste collection service.
2. If this is not possible, contact your local Grundfos representative.

U.S.A.

GRUNDFOS Pumps Corporation
17100 West 118th Terrace
Olathe, Kansas 66061
Phone: +1-913-227-3400
Telefax: +1-913-227-3500

Canada

GRUNDFOS Canada Inc.
2941 Brighton Road
Oakville, Ontario
L6H 6C9
Phone: +1-905 829 9533
Telefax: +1-905 829 9512

México

Bombas GRUNDFOS de
México S.A. de C.V.
Boulevard TLC No. 15
Parque Industrial Stiva
Aeropuerto
Apodaca, N.L.C.P. 66600
Phone: +52-81-8144 4000
Telefax: +52-81-8144 4010

L-JP-TL-001 07.11

98046345 07.11	US

ECM: 1079074

© 2011 Grundfos Pumps Corp.

The name Grundfos, the Grundfos logo, and the payoff Be–Think–Innovate are registered trademarks owned by Grundfos Management A/S or Grundfos A/S, Denmark. All rights reserved worldwide.

Subject to alterations.
