

WIRING INSTRUCTIONS

TITLE **TWO SPEED BAND SAW**

MILWAUKEE ELECTRIC TOOL CORP.

13135 WEST LISBON RD. BROOKFIELD, WIS

DATE
Nov. '74

BULLETIN
58-01-0720

Guide wires 3, 4, & 5 in hole. Then place insulator between sleeve and motor housing

INSULATOR
23-16-0475

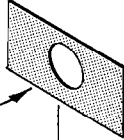

To brush holder clips

INSULATING
SLEEVE
23-48-0101

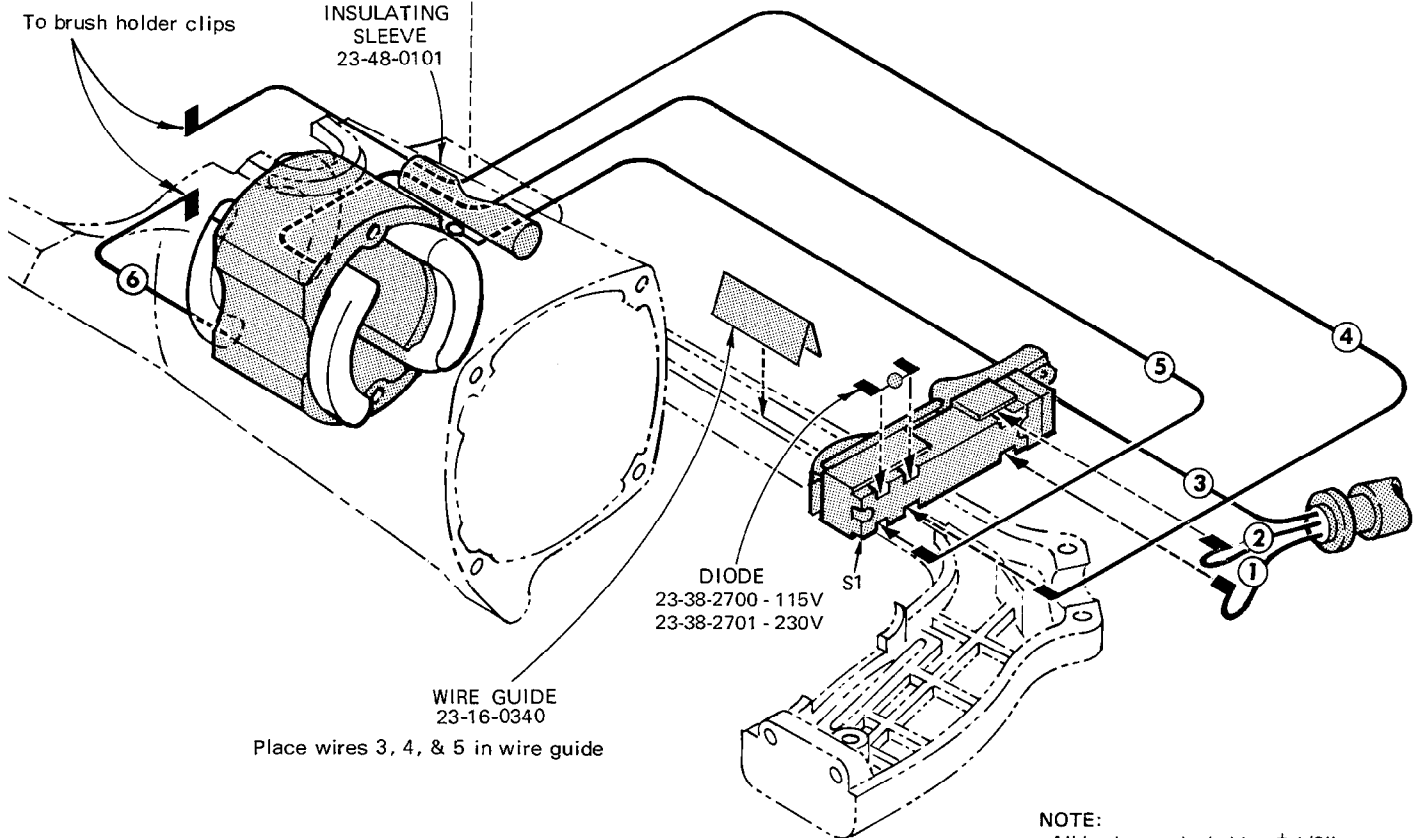

DIODE
23-38-2700 - 115V
23-38-2701 - 230V

WIRE GUIDE
23-16-0340

Place wires 3, 4, & 5 in wire guide

NOTE:

All leads must be held to $\pm 1/8''$.
All field leads to be measured from
and perpendicular to laminations.
All lead lengths are before stripping.

Refer to electrical parts chart for terminal and connector part nos.
and quantity required – see drawing for actual hook-up.

WIRING SPECIFICATIONS

Wire No.	Wire Color	Origin or Gauge	Length	Terminal				Connector					
				T1	T2	T3	T4	C1	C2	C3	C4		
1	White	Cord	2''	X									
2	Black	Cord	2''	X									
3	Green	Cord	9-1/4''		X								
4	Red	18	15''	XX									
5	Yellow	Field	15-1/2''	X									
6	Black	Field	1-3/4''	X									

ELECTRICAL PARTS

TERMINAL DESCRIPTION		
Code	Part No.	Qty.
T1	22-44-0090	6
T2	23-74-0390	1
CONNECTOR DESCRIPTION		
Code	Part No.	Qty.
SWITCH DESCRIPTION		
Code	Part No.	Qty.
S1	23-66-0755	1