

TITLE

MITER SAW

BULLETIN

MILWAUKEE ELECTRIC TOOL CORP. 13135 WEST LISBON RD. BROOKFIELD, WIS.

DATE
Aug. 2008

58-01-6925

AS AN AID TO REASSEMBLY, TAKE NOTE OF WIRE ROUTING AND POSITION IN WIRE GUIDES AND TRAPS WHILE DISMANTLING TOOL.

TWO WAY FEMALE CONNECTOR MUST BE CAREFULLY REMOVED IN ORDER TO ROUTE THIS END OF UPPER CONTROL HARNESS THROUGH MOTOR ARM ASSY. REATTACH AFTER HARNESS HAS BEEN ROUTED.



Opening for wires and harnesses as viewed from the other side of the Motor Arm Assembly.

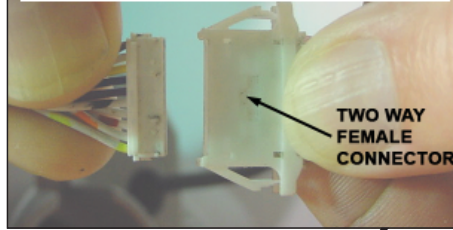
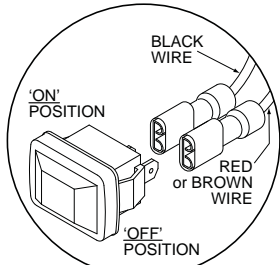

TWO WAY FEMALE CONNECTOR

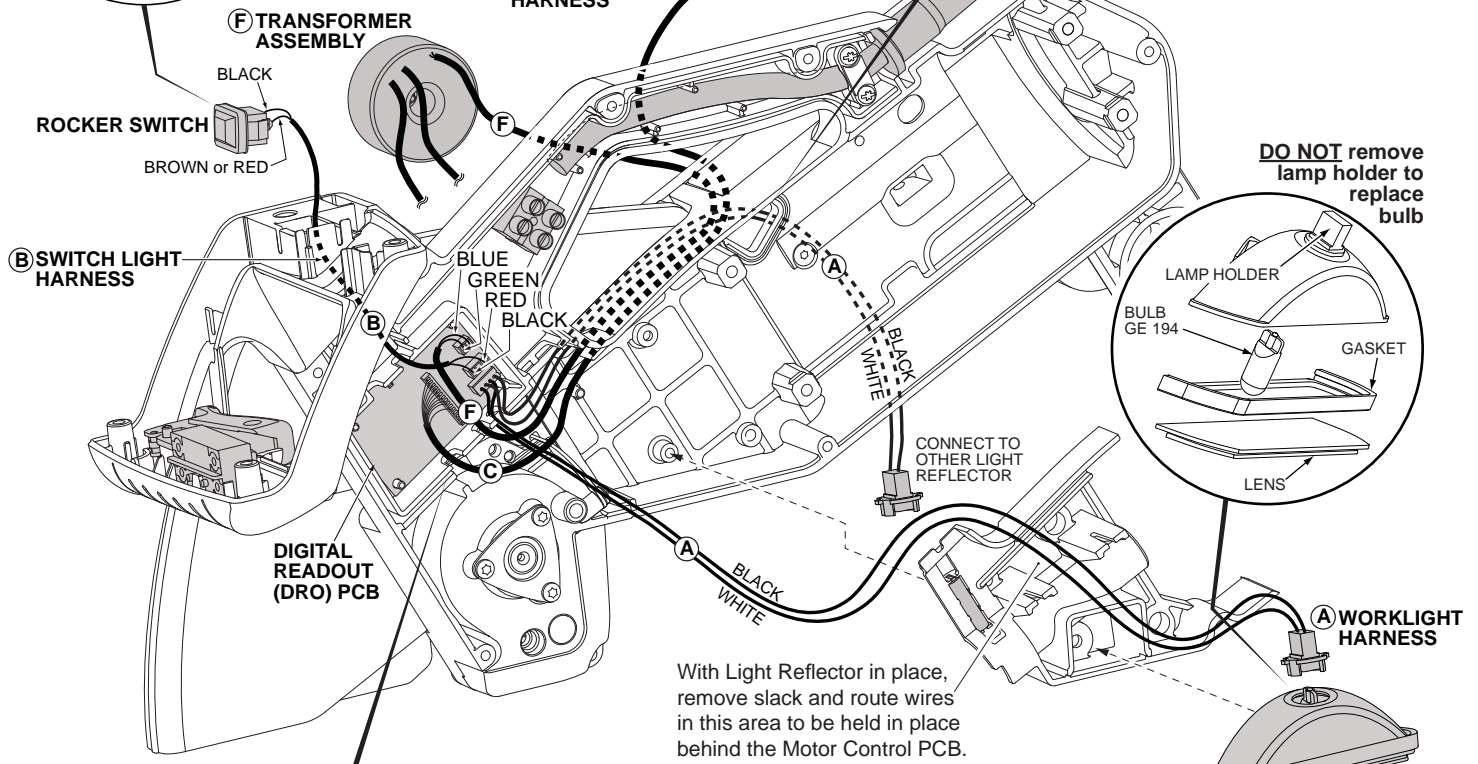

TRAPS

**(A) Worklights Harness
Cat. No. 23-94-8000**

- Connect 4 wire connector block to DRO (Digital Readout) PCB, Cat. No. 22-09-1060.
- Route black and white wires with lamp holders (2 places) as shown. Connect lamp holders to Light Reflector, Cat. No. 44-79-0040 (2 places). When replacing bulb, service through the lens side of assembly (see detail). **DO NOT remove lamp holder to replace bulb!** Use GE 194 Automotive Bulb.

**(B) Light Switch Harness
Cat. No. 23-94-8005**

- Connect 2 wire connector block to DRO (Digital Readout) PCB, Cat. No. 22-09-1060.
- Route wire harness as shown and connect black wire to the 'ON' terminal of the Rocker Switch, Cat. No. 23-66-3040. The other wire is red or brown and should be connected to the 'OFF' terminal.

**(F) Transformer
Cat. No. 23-81-0580**

- Route wire harness as shown and attach two wire connector block to DRO (Digital Readout) PCB, Cat. No. 22-09-1060

**(C) Upper Control Harness
Cat. No. 23-94-8012**

- Connect larger connector block to DRO (Digital Readout) PCB, Cat. No. 22-09-1060.
- Route wire harness as shown. The smaller connector block will attach to the Table Harness, Cat. No. 23-94-8027 (6955-20) or Cat. No. 23-94-8032 (6950-20). The two harnesses are joined by a double female adapter (see detail) that must be removed in order for the Upper Control Harness to pass through the top of Bevel Arm Assembly.

WIRING INSTRUCTIONS

TITLE

MITER SAW

BULLETIN

MILWAUKEE ELECTRIC TOOL CORP.

13135 WEST LISBON RD. BROOKFIELD, WIS.

58-01-6925

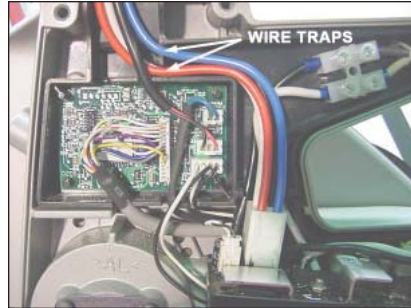
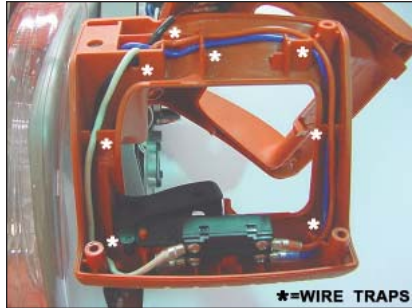

AS AN AID TO REASSEMBLY, TAKE NOTE OF WIRE ROUTING AND POSITION IN WIRE GUIDES AND TRAPS WHILE DISMANTLING TOOL.

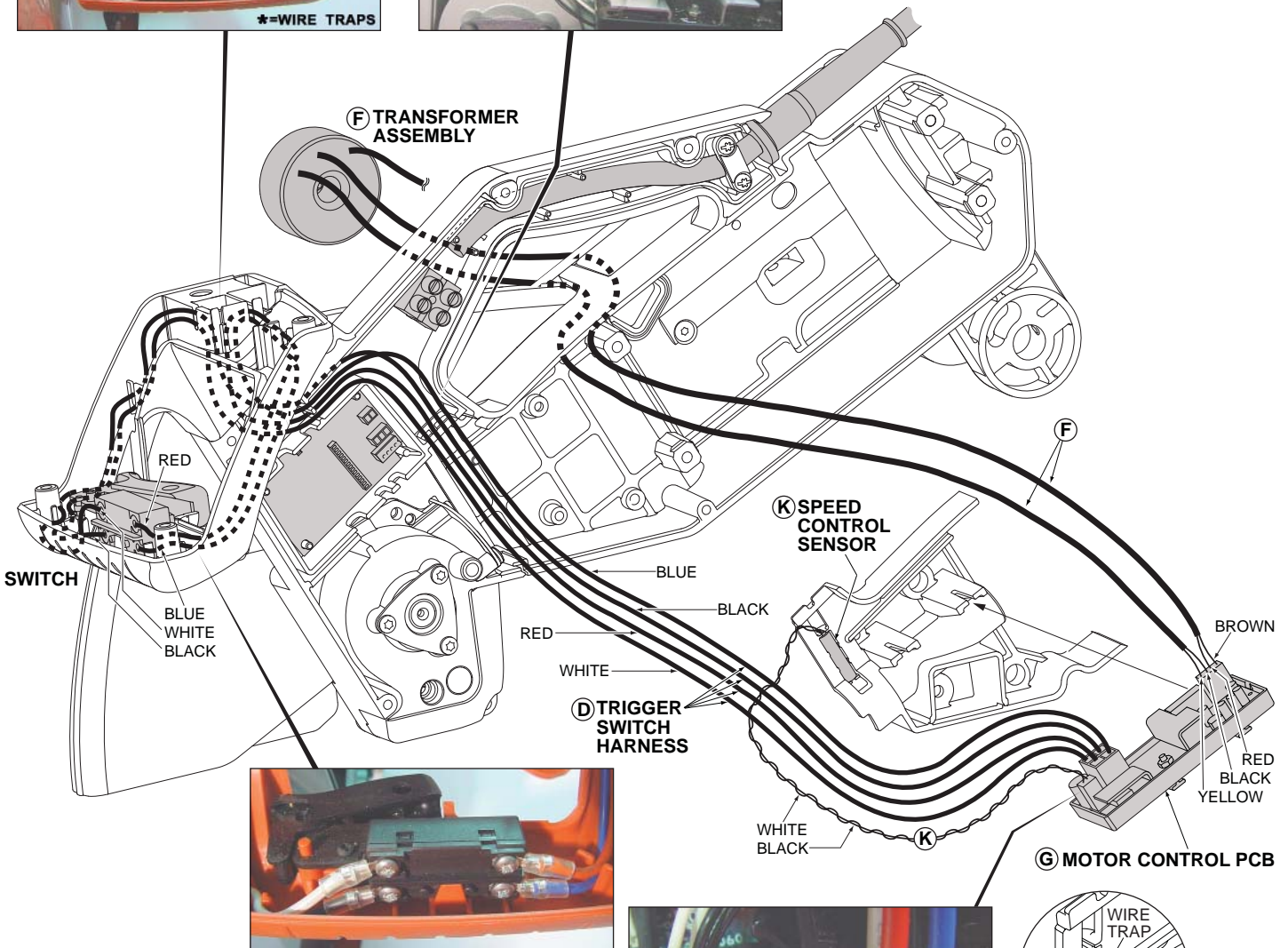

D Trigger Switch Harness

Cat. No. 23-94-8020

- Run black and white wires up through the opening in Bottom Handle. Route these wires along the left side of handle and connect to Switch, Cat No. 23-66-3035 as shown.
- Run red and blue wires up through the opening in Bottom Handle. Route these wires along the right side of handle and connect to Switch as shown.
- Connect 4 wire connector block to Motor Control PCB, Cat. No. 22-09-1590.
- Be sure to all wires are firmly pressed in wire traps as shown in details above.

F Transformer

Cat. No. 23-81-0580

- Route wire harness as shown and attach four wire connector block to Motor Control PCB, Cat. No. 22-09-1590.

K Speed Control Sensor

Cat. No. 23-80-0020

- Position Speed Control Sensor into cavity of Lower Tray. Place twisted black and white wires into trap above the cavity (see detail).
- Attach the two wire connector block to Motor Control PCB, Cat. No. 22-09-1590.

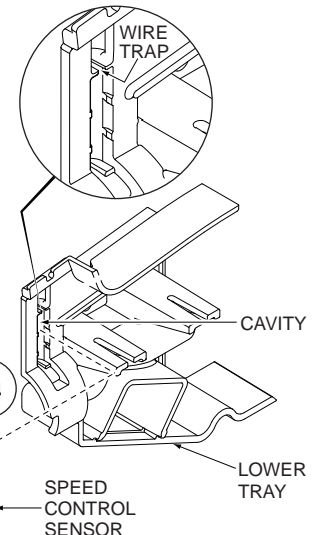
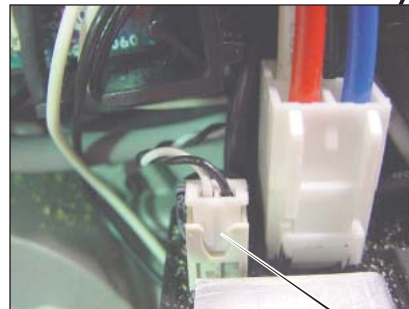

TITLE

MITER SAW

BULLETIN

MILWAUKEE ELECTRIC TOOL CORP.

13135 WEST LISBON RD. BROOKFIELD, WIS.

58-01-6925

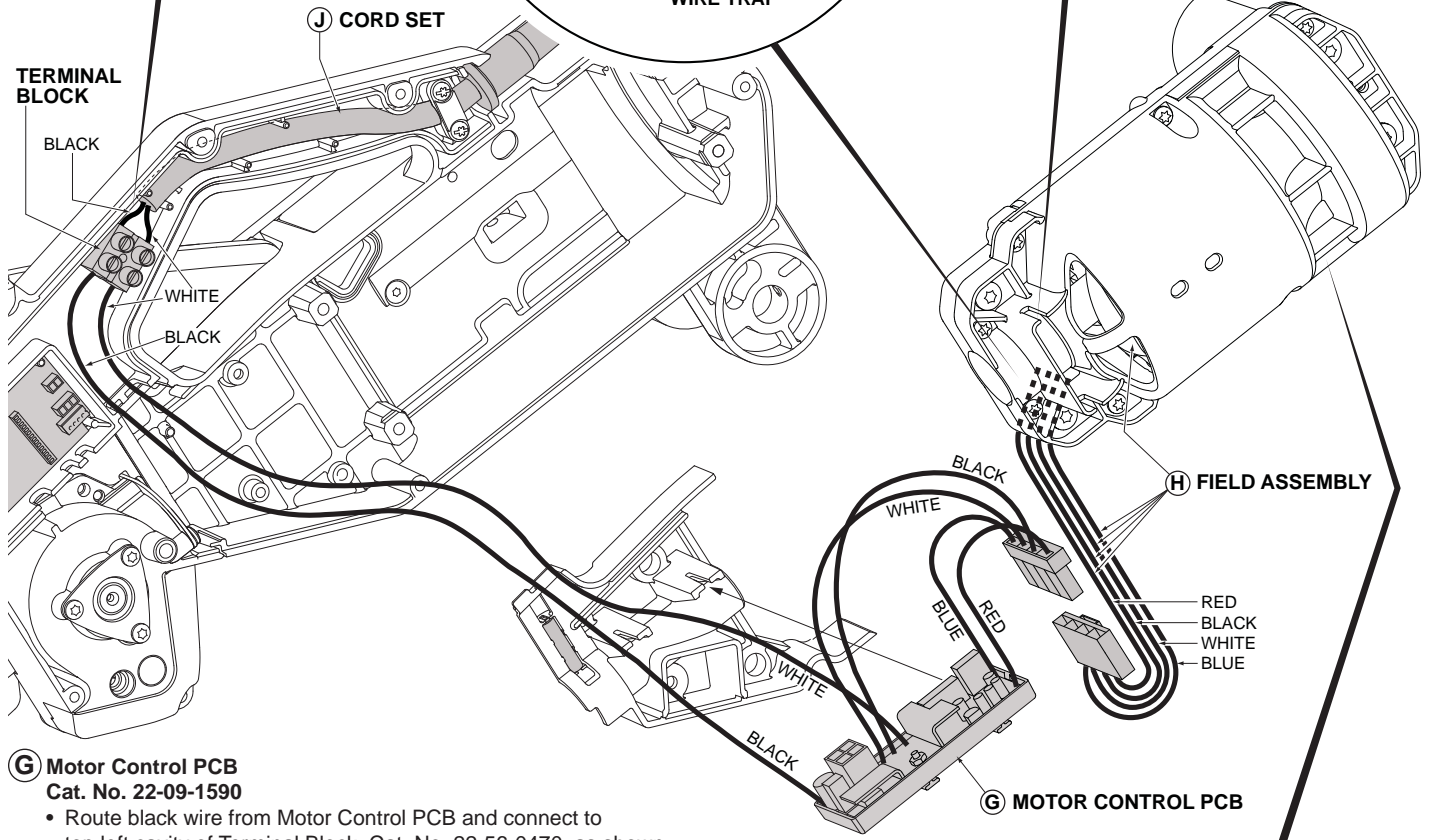
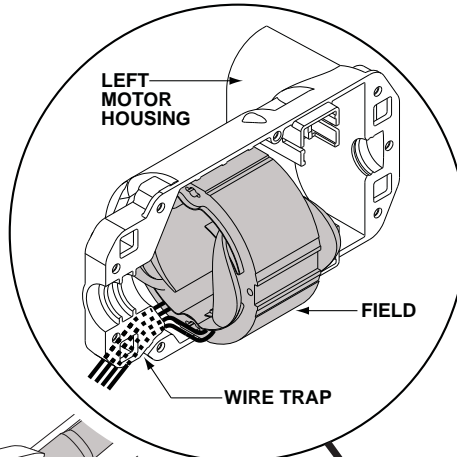
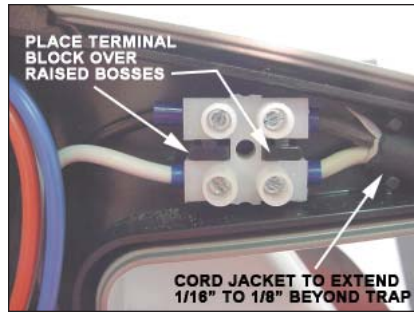

G Motor Control PCB
Cat. No. 22-09-1590

- Route black wire from Motor Control PCB and connect to top left cavity of Terminal Block, Cat. No. 22-56-0470, as shown.
- Route white wire from Motor Control PCB and connect to bottom left cavity of Terminal Block as shown.
- Secure Motor Control PCB by sliding tabs on the bottom of boat into slots on the Lower Tray. The four wire connector block (male) will attach to the 4 wire connector block (female) of the Field Assembly, Cat. No. 18-70-5000.

H Field Assembly
Cat. No. 18-70-5000

- Position Field in the Left Motor Housing with the four colored wires to the bottom. Place the colored wires firmly in the wire trap in the bottom of Motor Housing.
- On the other end of the Field, connect the white wires to the tabs on the Brush Holder Assemblies, Cat. No. 22-20-1020.
- With the Brush Assemblies, Armature Assembly and Field Assembly firmly in place, secure by fastening the Right Motor Housing to the Left Motor Housing.
- Attach 4 wire connector block (female) of the Field Assembly to the corresponding male connector block of the Motor Control PCB. Push joined connectors and wires into exterior cavity/wire traps of the Right Motor Housing (see illustration).

J Cord Set
Cat. No. 22-64-6495

- Route Cord Set in traps as shown, allowing cord jacket to extend 1/16" to 1/8" beyond the last trap. Secure the Cord Set with Cord Clamp.
- Connect black wire from Cord Set to top right cavity of Terminal Block and connect white wire to the bottom right of the Terminal Block.
- Place the Terminal Block with all wires attached over the raised bosses in the Upper Tray (see illustration).

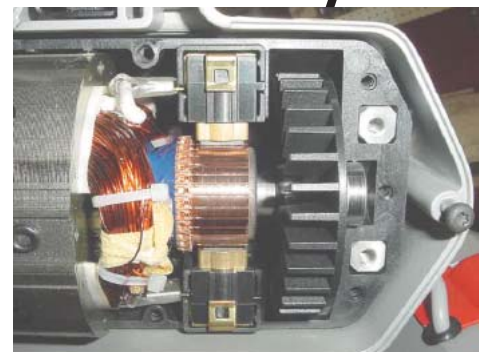

TITLE

MITER SAW

BULLETIN

MILWAUKEE ELECTRIC TOOL CORP. 13135 WEST LISBON RD. BROOKFIELD, WIS.

58-01-6925

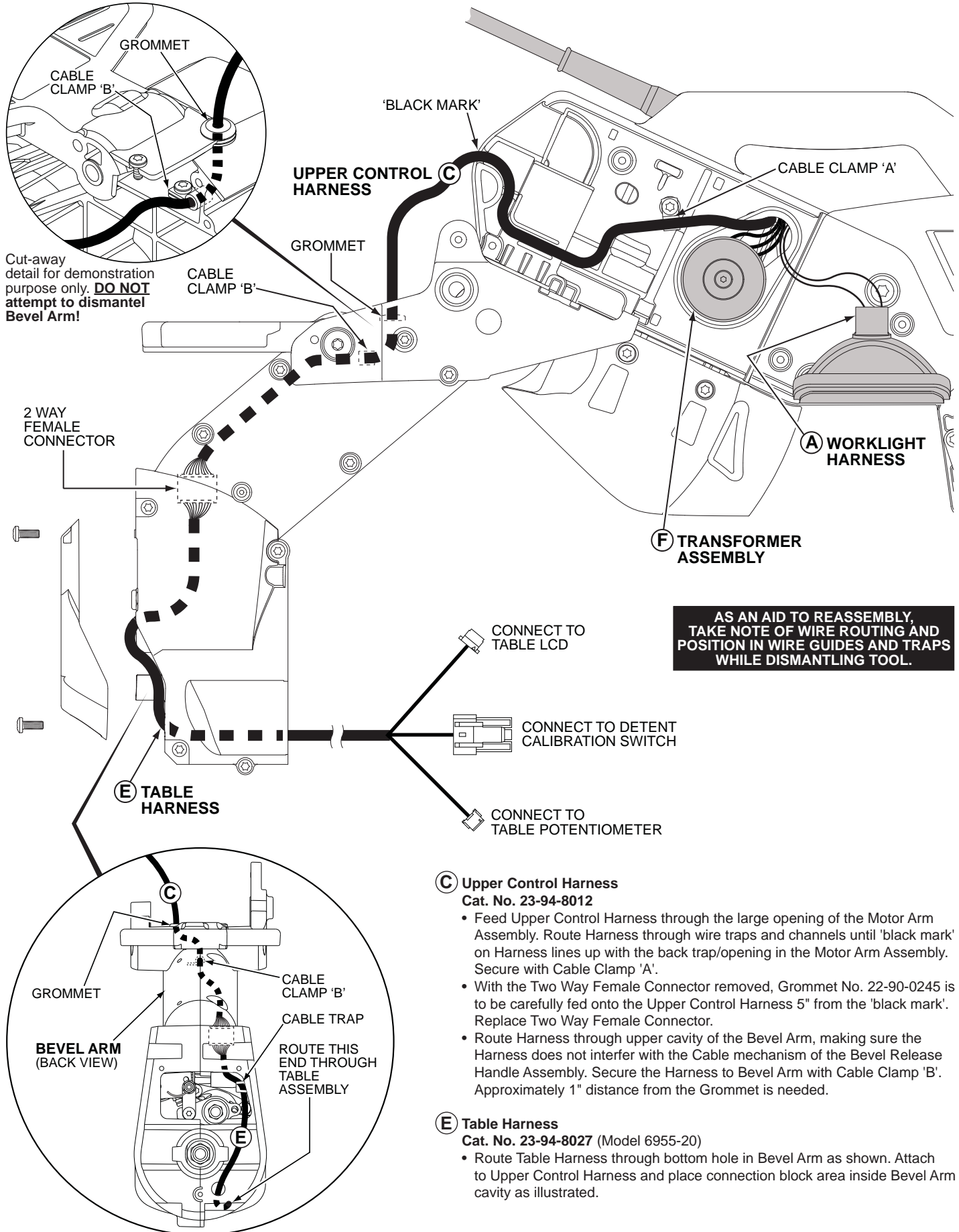

AS AN AID TO REASSEMBLY, TAKE NOTE OF WIRE ROUTING AND POSITION IN WIRE GUIDES AND TRAPS WHILE DISMANTLING TOOL.

C Upper Control Harness
Cat. No. 23-94-8012

- Feed Upper Control Harness through the large opening of the Motor Arm Assembly. Route Harness through wire traps and channels until 'black mark' on Harness lines up with the back trap/opening in the Motor Arm Assembly. Secure with Cable Clamp 'A'.
- With the Two Way Female Connector removed, Grommet No. 22-90-0245 is to be carefully fed onto the Upper Control Harness 5" from the 'black mark'. Replace Two Way Female Connector.
- Route Harness through upper cavity of the Bevel Arm, making sure the Harness does not interfere with the Cable mechanism of the Bevel Release Handle Assembly. Secure the Harness to Bevel Arm with Cable Clamp 'B'. Approximately 1" distance from the Grommet is needed.

E Table Harness
Cat. No. 23-94-8027 (Model 6955-20)

- Route Table Harness through bottom hole in Bevel Arm as shown. Attach to Upper Control Harness and place connection block area inside Bevel Arm cavity as illustrated.

WIRING INSTRUCTIONS

TITLE

MITER SAW

BULLETIN

MILWAUKEE ELECTRIC TOOL CORP.

13135 WEST LISBON RD. BROOKFIELD, WIS.

58-01-6925

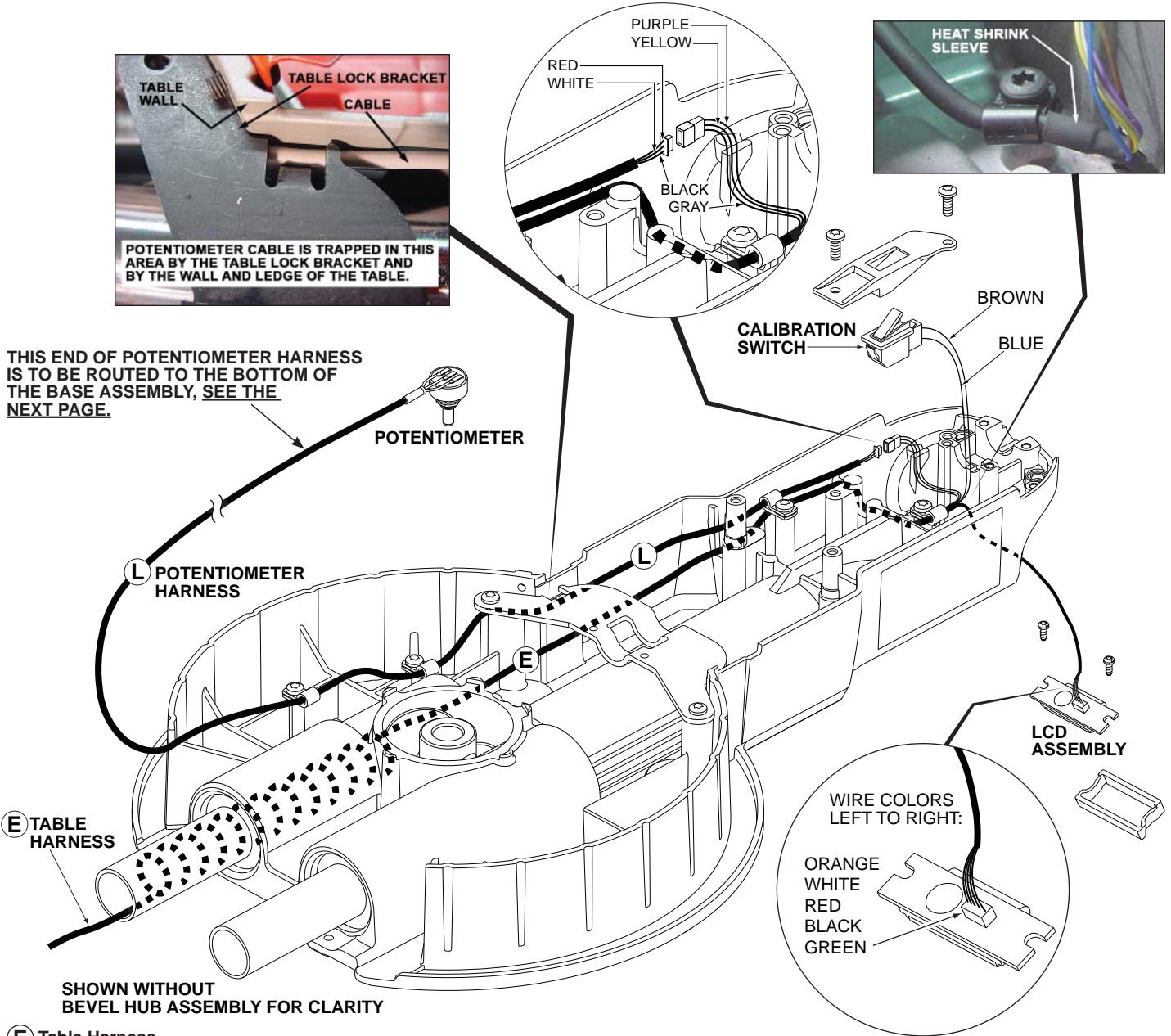

AS AN AID TO REASSEMBLY, TAKE NOTE OF WIRE ROUTING AND POSITION IN WIRE GUIDES AND TRAPS WHILE DISMANTLING TOOL.

(E) Table Harness

Cat. No. 23-94-8027 (Model 6955-20)

- Route Table Harness through Slide Tube and the bottom of the Table Assembly, as shown. (The harness is coiled to allow for the travel of the saw along the Slide Tubes). Secure the Harness with a Cable Clamp directly behind the heat shrink sleeve (see detail).
- Attach the three wire terminal block (purple, yellow and gray) to the three wire connector block (red, white and black) of the Potentiometer Harness.
- Attach the two wire connector block (brown and blue) to the Calibration Switch.
- Route the five wire portion of the harness (orange, white, red, black and green) through the opening in the front of the Table Assembly and connect to the LCD Assembly.

(L) Potentiometer Harness

Cat. No. 23-45-0010 (Model 6955-20)

- Route Potentiometer Harness through the bottom of the Table Assembly, as shown. Secure harness in Cable Clamps and under Table Lock Bracket, as illustrated above and below.
- Potentiometer and the balance of the harness are to be routed into the Base Assembly, see the next page.

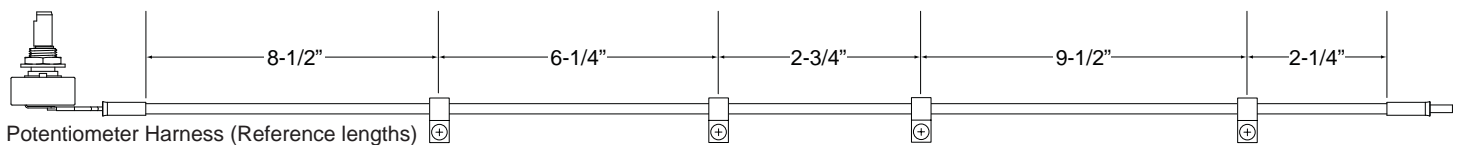

TITLE

MITER SAW

BULLETIN

MILWAUKEE ELECTRIC TOOL CORP.

13135 WEST LISBON RD. BROOKFIELD, WIS.

58-01-6925

*Flat side of the Potentiometer brass shaft must be positioned / turned 180° from cable attachment wires prior to installing shaft into Tolerance Ring. Failure to properly position the brass shaft will limit the adjustment range.

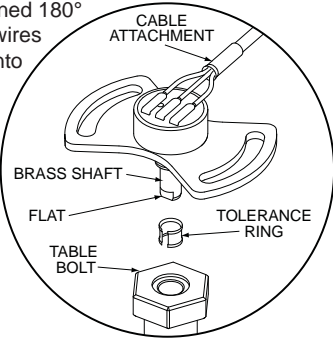

AS AN AID TO REASSEMBLY, TAKE NOTE OF WIRE ROUTING AND POSITION IN WIRE GUIDES AND TRAPS WHILE DISMANTLING TOOL.

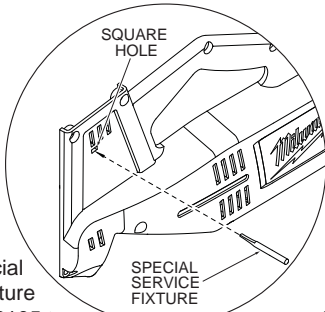

**Use Special Service Fixture No. 61-10-0105 to reset the Digital Readout (DRO) Board. Insert fixture into the small square hole located in the Motor Case Cover as shown.

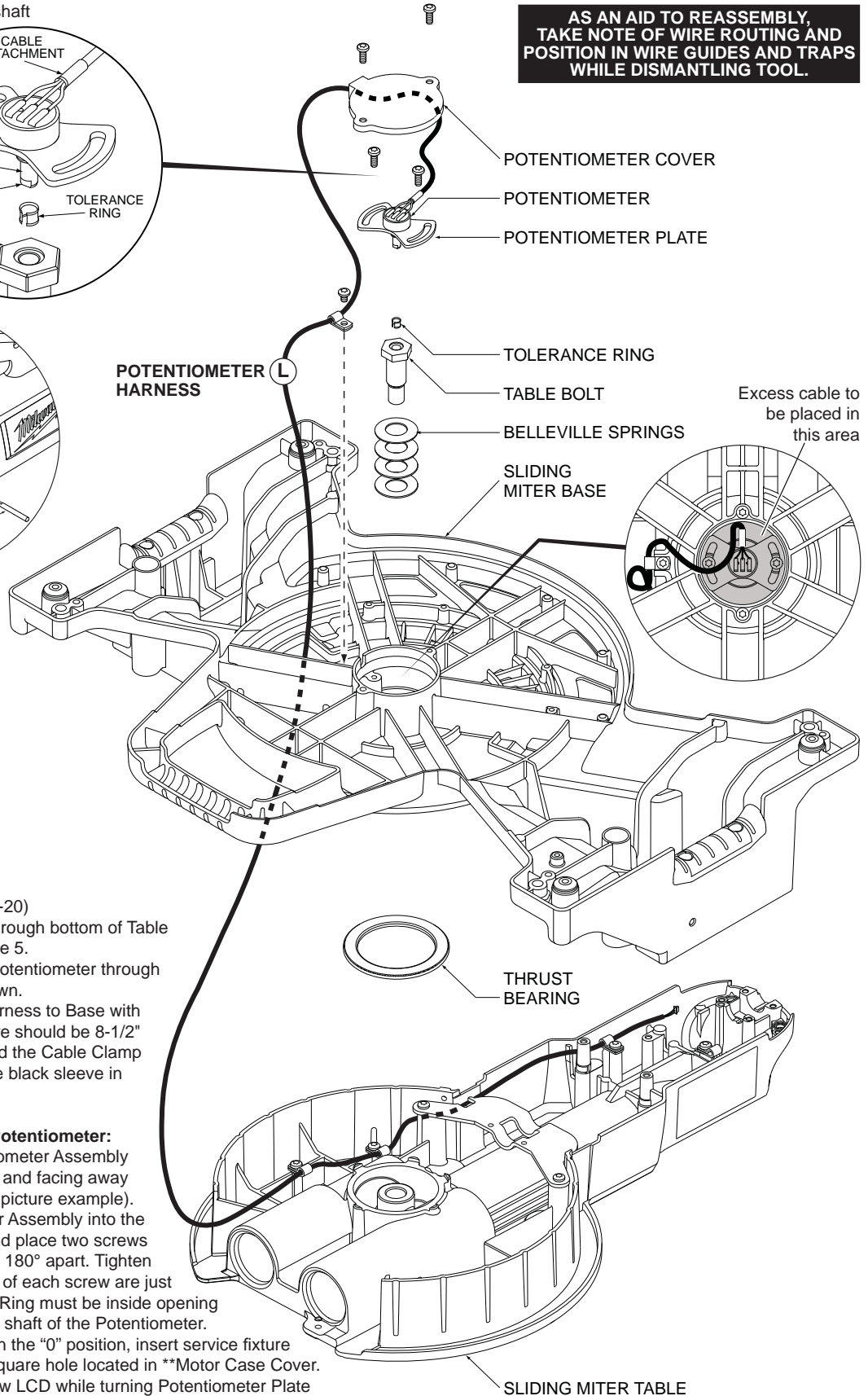

L Potentiometer Harness

Cat. No. 23-45-0010 (Model 6955-20)

- Route Potentiometer Harness through bottom of Table and secure as described on page 5.
- Route remaining Harness and Potentiometer through the opening in the Base, as shown.
- In the same opening, secure Harness to Base with Cable Clamp as illustrated. There should be 8-1/2" of the Harness extending beyond the Cable Clamp (measured from the clamp to the black sleeve in front of the Potentiometer).

Adjustment of "zero" on Base Potentiometer:

- Position the shaft of the Potentiometer Assembly with the flat parallel to lead tabs and facing away from cable lead wires. (Refer to picture example).
- Install shaft of the Potentiometer Assembly into the center opening of *Table Bolt and place two screws through the Potentiometer Plate 180° apart. Tighten each screw down until the head of each screw are just touching the plate. *(Tolerance Ring must be inside opening in the Table Bolt and around the shaft of the Potentiometer).
- With tool unplugged and Table in the "0" position, insert service fixture No. 61-10-0105 into the small square hole located in **Motor Case Cover.
- Plug tool into power source. View LCD while turning Potentiometer Plate until digital read out reads 1° or less.
- While holding the Potentiometer Plate steady, securely tighten the two mounting plate screws referenced in paragraph above.
- Route / place any excess Potentiometer cable into area provided under Base and place Cover over Potentiometer Assembly and secure using two screws.

TITLE

MITER SAW

MILWAUKEE ELECTRIC TOOL CORP.

13135 WEST LISBON RD. BROOKFIELD, WIS.

BULLETIN

58-01-6925

SIMPLIFIED WIRING SCHEMATIC (For Reference Only)

