



# SYMMONS® Symmetrix®

## Lavatory Faucet S-250 Series

### Installation and Service Instructions

Caution: Be sure to turn off hot and cold water supplies before installing or servicing faucet.

#### Installation

1. Push faucet supplies with rubber gasket through holes in sink (make sure gasket [LL-126] is between faucet and sink). Secure faucet to sink by tightening flange nuts (LL-125) from underside. (If sink or counter surface is uneven, use putty or sealant to make proper seal under base.)
2. Connect hot supply to left tube and cold supply to right tube using appropriate connectors.
3. Pop-up drain installation:
  - a) Remove pop-up plug, tail piece and flange from the drain body. Make sure that locknut is threaded all the way down onto the body with flat friction washer in middle and beveled washer on top.
  - b) Apply plumbers putty or sealant to bottom of flange.
  - c) Install drain body through drain opening in lavatory and screw flange onto the drain body making sure that the threads are completely engaged for proper sealing and strength of the connection. Apply joint compound to all threaded parts to insure proper seal.
  - d) Tighten locknut to compress the beveled flange evenly across the bottom of the drain opening taking care not to over tighten the locknut, causing damage to the lavatory.
  - e) Remove one of two ball washers from inside the threaded cavity. Insert pop-up plug and pivot rod into body. Add one ball washer (the second ball washer should remain inside the body) to the outside of the ball. Tighten the retaining nut until the ball is seated on the internal and external ball washers. Note: The pop-up plug can be installed either in the removable or non-removable position, depending on the location of the hole located in the guide at the bottom of the plug.
  - f) Slide the pivot rod through one side of the spring clip, then the appropriate adjustment hole and then other side of the spring clip.



S-250-1



S-250-1-LWG

- g) Insert lift rod through faucet housing and the top of the lift strap and secure it in place by tightening the screw. Note: To insure proper operation of lift rod and pop-up, some adjustment of the linkage may be required. There are two possible adjustment points: 1) lift strap to lift rod and 2) lift strap to pivot rod.
4. It is very important to thoroughly flush the supply lines to prevent foreign matter, i.e. copper chips, sand, stones, etc. from damaging the sealing surfaces of cartridge. Remove aerator and open hot and cold to full open then open both supplies. Let water run through hot and cold long enough to flush supply lines thoroughly. Shut off faucet and replace aerator. Check for leaks.

#### Replacing handle

1. Remove screw from top of handle. Remove red or blue washer and then remove handle (LL-122) or (LL-123).
2. Reassemble handle (LL-122) or (LL-123) in reverse fashion.

#### Replacing cartridge

1. Remove screw from top of handle. Remove red or blue washer and then remove handle (LL-122) or (LL-123).
2. Unthread cartridge cover (LL-127) from faucet.
3. Place wrench on cartridge (LL-124) hex nut, turn wrench counter clockwise until cartridge is removed.
4. Install new cartridge (LL-124). Turn cartridge with wrench until cartridge does not turn easily then turn 1/4 to 1/2 turn further.
5. Reassemble cartridge cover (LL-127).
6. Reassemble (LL-122) or (LL-123) handle in reverse fashion.

## Dimensions *Symmetrix Lavatory Faucet, S-250 Series*

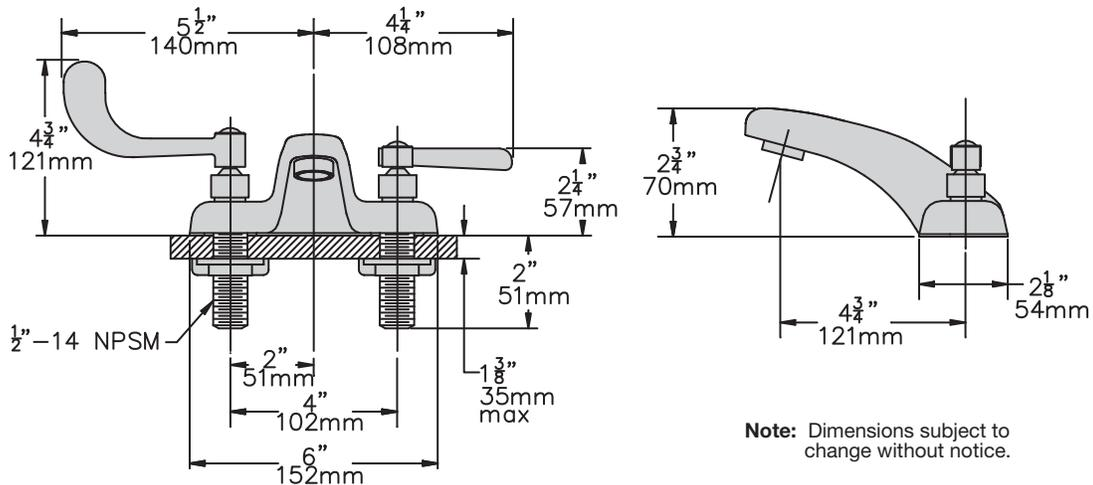

## Parts Assembly *Symmetrix Lavatory Faucet, S-250 Series*

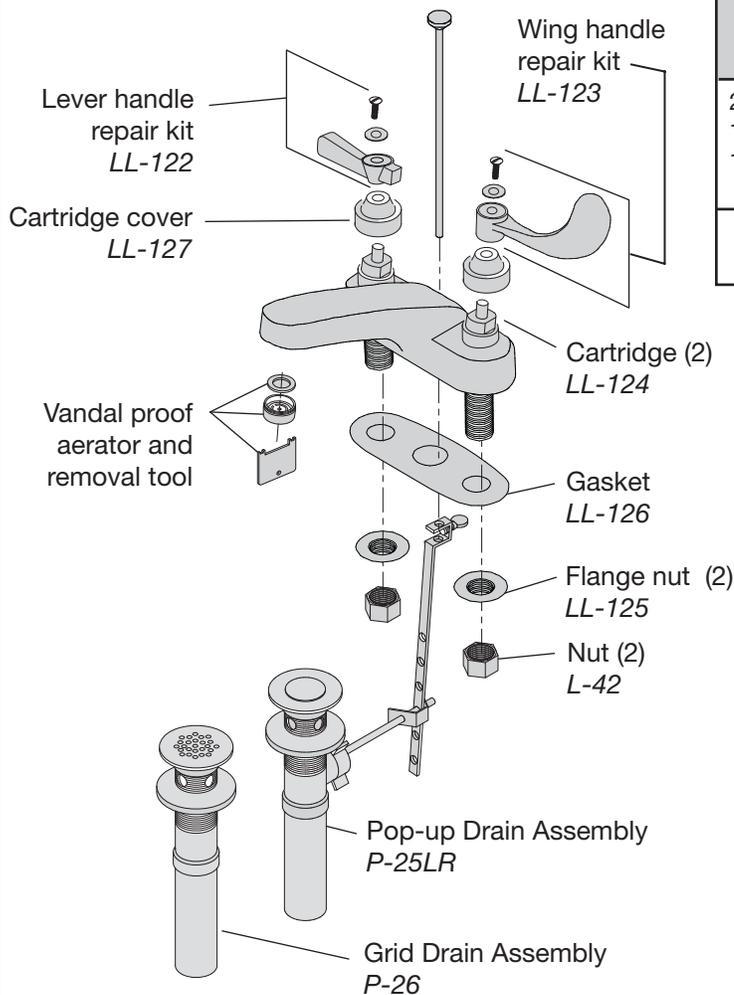

Aerator (flow regulator)	Part Number	
	Standard Aerator	Vandal Resistant with removal tool
2.2 gpm (8.3L/min)	LN-15*	LN-101*
1.5 gpm (5.7L/min)	FLR-111-1.5*	----
1.0 gpm (3.8L/min)	FLR-111-1.0*	----
.5 gpm (1.9L/min)	----	LN-100*
Removal tool part number, LL-60K		

\* Note: When ordering replacements parts for faucets with an optional decorative finish, append appropriate three letter finish suffix code to part numbers marked with an asterisk (\*).

### Ordering replacement parts:

Call Symmons customer service at (800) 796-6667, (781) 848-2250 M-F 8:00 am - 7:30 pm EST or check our website at [www.symmons.com](http://www.symmons.com) for a list of Symmons distributors.