

#### Architect/Engineering Specifications:

Open epoxy coated steel hose reel with high flow spray valve, 3/8" x 50' heavy duty non-marking hose, ratcheting system, multi-fit bracket, adjustable hose bumper, 3/8" NPT female inlet and 3' connector hose.

Job Name	_____
Model Specified	_____ Quantity _____
Variations Specified	_____
Date	_____

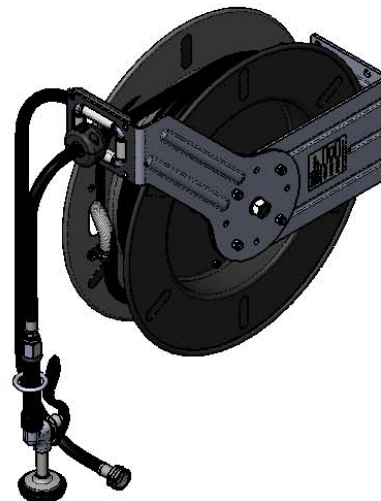
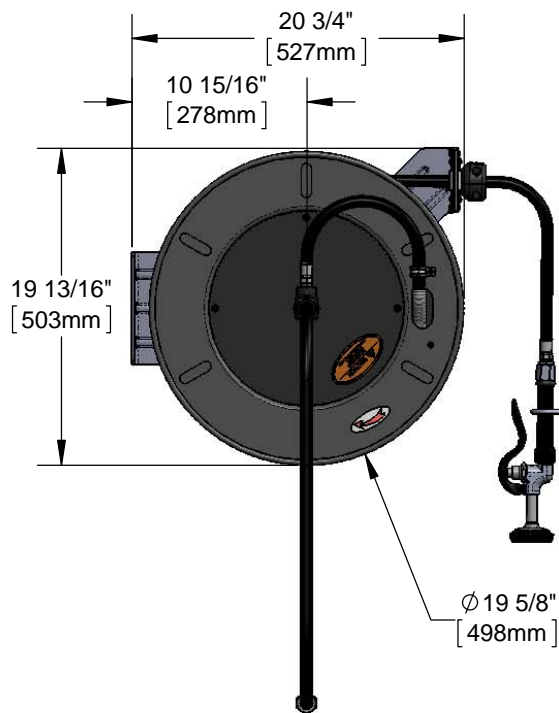

#### Features & Benefits:

- Open coated hose reel
- Black high flow spray valve
- 3/8" x 50' heavy duty non-marking hose rated to 300 PSI
- Ratcheting system holds the length of hose until a slight tug to retract automatically
- 3/8" NPT female inlet
- Furnished with 3' connector hose, 3/8" NPT male x garden hose swivel female
- Adjustable hose bumper
- Multi-fit bracket for wall, ceiling or under counter mounting
- Material: Epoxy coated steel open reel and wall bracket, polished chrome plated spray valve

#### Product Compliance:

- EPAAct 2005 Non-Compliant (PRSV)
- NSF 61 Exempt (Non-Potable)

#### Warranty: Two Year (Limited)

- Hose: 90 Day (Limited)

#### Performance Data:

- Pressure: 20 - 125 psi
- Temperature: 40 °F - 140 °F
- Flow Rate: 2.53 GPM @ 60 psi