



# Epoxy Coated Retractable Hose Reels

TAG:

## 5HR-242-GH

## Open Epoxy Coated Steel Hose Reel

### Architect/Engineering Specifications:

Open epoxy coated steel hose reel, 3/8" x 50' heavy duty non-marking hose, ratcheting system, multi-fit bracket, adjustable hose bumper and 3/8" NPT female inlet and 3/8" NPT male outlet.

Job Name _____
Model Specified _____ Quantity _____
Variations Specified _____
Date _____

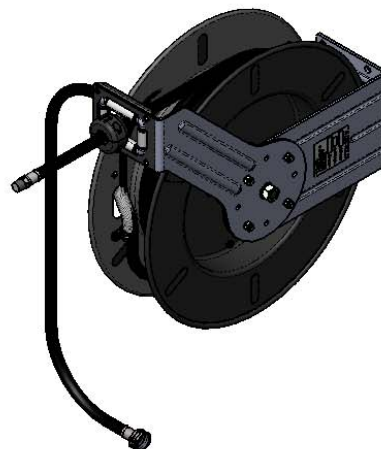
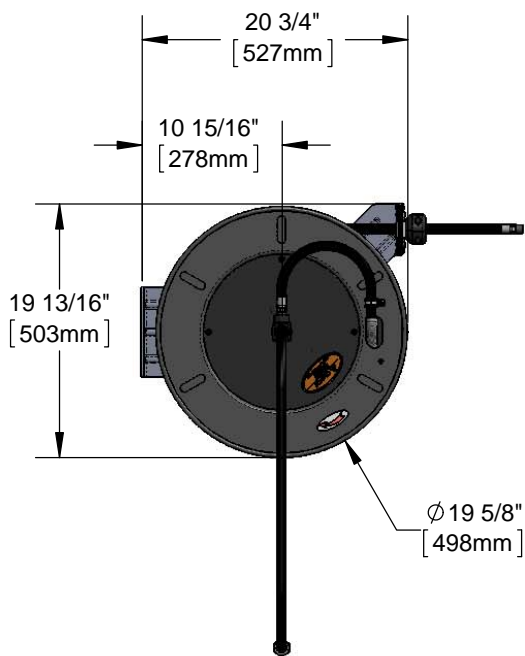

### Features & Benefits:

- Open coated hose reel
- 3/8" x 50' heavy duty non-marking hose rated to 300 PSI
- Ratcheting system holds the length of hose until a slight tug to retract automatically
- 3/8" NPT female inlet
- 3/8" NPT male outlet
- Furnished with 3' connector hose, 3/8" NPT male x garden hose swivel female
- Adjustable hose bumper
- Multi-fit bracket for wall, ceiling or under counter mounting
- Material: Epoxy coated steel open reel and wall bracket

### Product Compliance:

- NSF 61 Exempt (Non-Potable)

### Warranty: Two Year (Limited)

- Hose: 90 Day (Limited)

### Performance Data:

- Pressure: 20 - 125 psi
- Temperature: 40°F - 140°F
- Flow Rate: 5.31 GPM @ 60 psi



equip Foodservice Accessories



• 2 Saddleback Cove • Travelers Rest, SC 29690  
Ph 800-891-4808 • Fax 800-868-0084  
www.tsbrass.com

Date: 02/23/16