



SERVICE PARTS LIST

BULLETIN NO.
54-05-0100

SPECIFY CATALOG NO. AND SERIAL NO. WHEN ORDERING PARTS		REVISED BULLETIN	DATE
M18™ COMPACT VACUUM			Nov. 2016
CATALOG NO. 0882-20	STARTING SERIAL NO. H64A	WIRING INSTRUCTION	

EXAMPLE:

00
0

Component Parts (Small #) Are Included
When Ordering The Assembly (Large #).

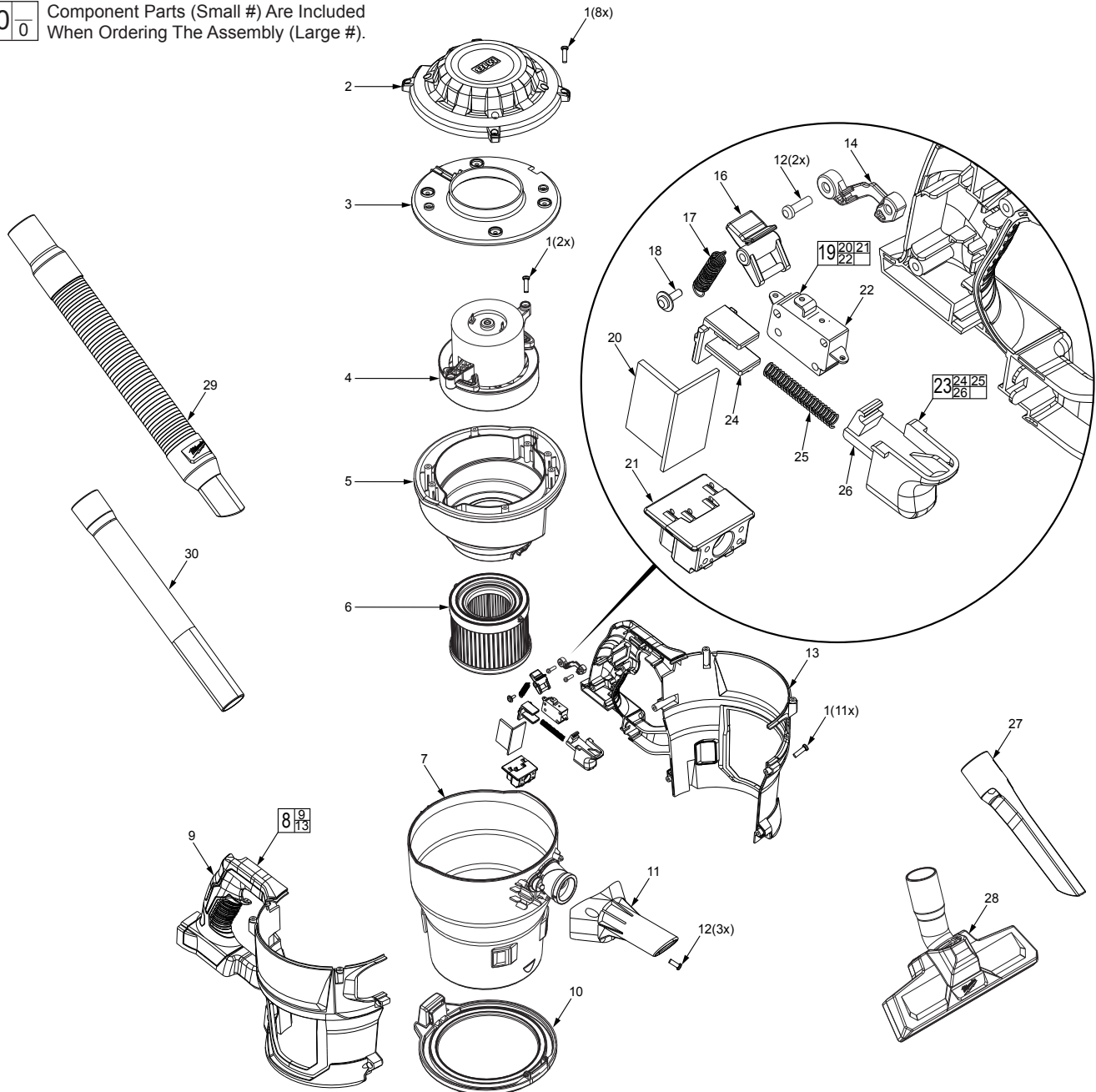

FIG.	PART NO.	DESCRIPTION OF PART	NO. REQ.	FIG.	PART NO.	DESCRIPTION OF PART	NO. REQ.
1	05-88-0006	M3 x 16 Screw	(21)	17	40-50-0231	Spring	(1)
2	14-38-0409	Top Cover	(1)	18	06-81-0401	Washer Head Screw	(1)
3	31-50-0891	Motor Inner Housing	(1)	19	14-20-0109	Electronics Assembly (wires not shown)	(1)
4	14-30-2435	Motor Assembly	(1)	20	-----	PCBA	(1)
5	42-14-0026	Deflector	(1)	21	-----	Battery Terminal Connector Block	(1)
6	49-90-0160	Filter	(1)	22	-----	On/Off Switch	(1)
7	42-51-0386	Canister	(1)	23	23-66-0056	Trigger Assembly	(1)
8	14-38-0536	Housing Assembly	(1)	24	-----	Trigger Holder	(1)
9	-----	Right Housing	(1)	25	-----	Trigger Spring	(1)
10	31-15-0023	Canister Lid Assembly	(1)	26	-----	Trigger	(1)
11	45-76-0260	Inlet	(1)	27	31-01-0865	Crevice Tool	(1)
12	05-88-0007	M3 x 10 Screw	(5)	28	31-01-0860	Floor Tool	(1)
13	-----	Left Housing w/ Pin	(1)	29	14-37-0170	Hose	(1)
14	44-66-0864	Press Plate	(1)	30	45-76-0990	Extension Tube	(1)
16	23-66-0038	Switch Lock-On Button	(1)	31	12-20-0097	Service Nameplate (not shown)	(1)