

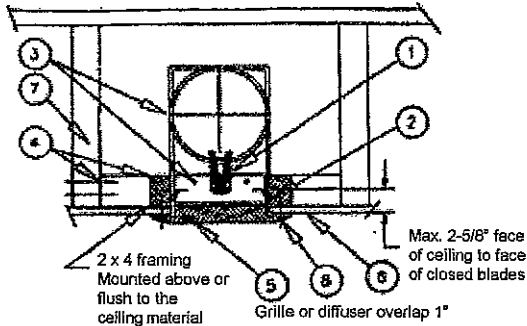

# 2700 Series Ceiling Radiation Damper Alternative Installation Instructions



## General Install Instructions Models 2701 or 2702 (Square or Rectangular)

1. Ceiling Radiation Damper
2. 22 gauge galv steel sleeve with (4)  $\frac{3}{4}$ " flanges. Sleeve spot welded or riveted to 2700 on 6" centers max.
3. 30 gauge min. sheet metal register/plenum box secured to 2x4 framing with (4) #6 x  $\frac{3}{4}$ " long flat head sheet metal screws (4) places min.
4. 2 x 4 framing (2) places minimum. Secured to joists or trusses with #6 to #10 common nails, or #8 to #10 drywall screws (2) places minimum per connection
5. Steel grille, diffuser, register, or drop ducting
6. Ceiling: Gypsum wallboard, acoustical panel, or lay-in tile
7. Floor or roof trusses, joists, or support beams
8. Assembly fastened to 2 x 4 frame with #10 screws (2) places minimum.

Model 2701 and 2702 Ceiling Radiation Dampers are Classified to UL 555C as 3 Hour or less heat barriers illustrated in the UL Fire Resistance Directory. Refer to the partition classification information in the Fire Resistance Directory regarding the use of these dampers in the various floor –ceiling and roof-ceiling assemblies. Ceiling dampers and the associated components (diffusers, grilles, ducts, etc) which are to be constructed of steel are installed in the ceiling to maintain the hourly ratings of these rated floor-ceiling, roof-ceiling assemblies. The combination of damper, partition and installation establish this 3 hour or less Underwriters Laboratory Fire Rating.

Shoemaker Manufacturing Model 2701 or 2702 are laboratory approved for installation in all 3 hour or less rated fire barriers listed in the UL Fire Resistance Directory, where fire barriers are shown with partition penetrations. Fire barriers without penetrations, and fire barriers not listed in the UL Fire Resistance Directory are not approved for installations and require the use of "Special" assemblies.

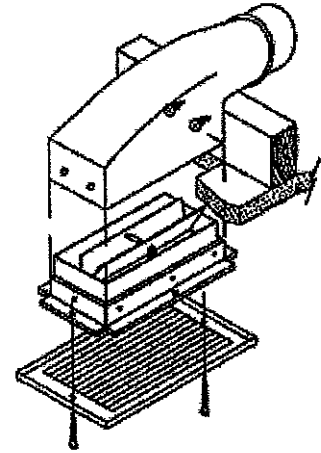

## Installation Instructions:

1. Before installing 2701 or 2702 damper, open the blades and hook the fusible link over the link catch on the opposite blade. Bend down the link catch to secure the link in position.
2. Measure the actual spacing between the joists or other structural members allowing for 2 x 4 frame mounting. Cut and fasten the frames to the trusses or joists on both ends, spacing frames to accurately accommodate plenum sizes. 2 x 4 frames are fastened to joists or other structural members with a minimum of two fasteners for each mounting point using #6-#10 common nails or #8-#10 drywall screws of the appropriate length.
3. Install the register box, plenum, boot, into the frame at the appropriate height allowing the damper and sleeve assembly. Plenums are fastened to joists or other structural members with a minimum of two fasteners for each mounting point using #8-#10 flat head screws  $\frac{3}{4}$ " long minimum. When a full frame is used (8) fasteners are required. Test the plenum box location, final sizing, and damper function prior to assembly of gypsum or ceiling materials. The 2700 series and flanged sleeve must join the plenum box with no greater than 1/8" assembly spacing.
4. Secure the ducting to the plenum collar
5. After ceiling materials have been installed, install and fasten the 2700 Series/Sleeve/Grille assemblies using a minimum of (2) #8-#10 x 3" long sheet metal, wood, or drywall screws through the ceiling material and into the 2 x 4 framing. Check the damper function upon completion.

NOTE: Ceiling material damper/sleeve final assembly clearances can be no greater than 1/8" maximum.



APPLIED RESEARCH LABORATORIES (UL555C)  
CLASSIFIED CEILING RADIATION DAMPERS.  
FIRE RESISTANCE RATED 3 HOURS. FOR USE  
IN UL CLASSIFIED BUILDING MATERIALS  
RATED 3 HOURS OR LESS.

**ALL INSTALLATIONS ARE SUBJECT TO LOCAL  
AUTHORITY APPROVAL PRIOR TO ORDERING  
DAMPERS AND DAMPER INSTALLATION**

104 Montgomery Avenue  
Cle Elum, WA 98922

Tel: (866) 940-0696  
Fax: (509) 674-4420  
[sm@shoemakermfg.com](mailto:sm@shoemakermfg.com)

visit us online:  
[www.shoemakermfg.com](http://www.shoemakermfg.com)

