



PIPE TOOLS & VISES
SINCE 1896

Hydrostatic Test Pump Operating Instructions

Cat. No. HTP300
Item Code: #08150
Maximum PSI: 300

Cat. No. HTP1000
Item Code: #08160
Maximum PSI: 1000

Siphon Method:

Fill the water line to be tested using a filtered input hose. Fill the pump's intake hose. Place the intake hose into the source. Pump until water comes out of the outlet with little or no air. Connect the output hose to the water line. Bring the line to pressure by pumping the handle. Watch the gauge while pumping. Close the valve 90 degrees while nearing the test pressure. Shut the valve completely after reaching the test pressure. Dropping pressure indicates a leak in the line.

City Water Method:

Verify the pump's ball valve is shut. Connect the output hose to the water line being tested. Connect the input hose to city water. Open the pump's ball valve and turn on the water. Bring the line to pressure by pumping the handle. Watch the gauge while pumping. Close the valve 90 degrees while nearing the test pressure. Shut the valve completely after reaching the test pressure. Dropping pressure indicates a leak in the line.

Note:

This pump is designed for water only. If the pump does not build up pressure and water is coming out of the relief valve, try the following: Close the valve and pump the handle quickly. Take care not to spike the gauge. Continue pumping until pressure increases without water coming out the relief valve. The pumping action should unstick the relief valve ball.

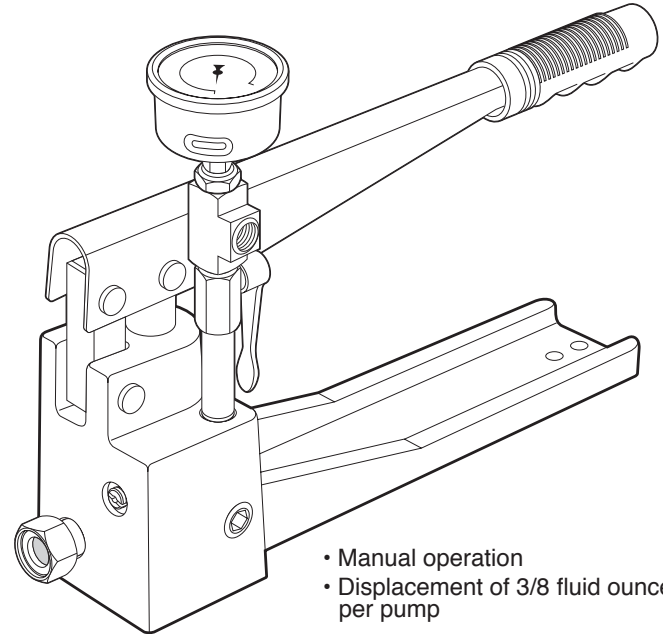

- Manual operation
- Displacement of 3/8 fluid ounce per pump

Reed Manufacturing Company
1425 West 8th Street
Erie, PA 16502 USA

QUALITY
& Service
that Last a Lifetime

Phone: 800-666-3691 or 814-452-3691
Fax: 800-456-1697 or 814-455-1697
www.reedmfgco.com

0915-58167