

Electric Eel®

MODEL RF Drain Cleaning Machine

Operator's Manual



FOR YOUR SAFETY

Before you operate or maintenance this equipment, READ this manual carefully and completely!

Purchase Date: _____

Serial Number: _____



ELECTRIC EEL MANUFACTURING CO., INC.

501 West Leffel Lane, Springfield, Ohio 45506

Call Toll Free: (800) 833-1212 (937) 323-4644

FAX: (937) 323-3767 www.electriceel.com

Proudly Made in The USA Since 1939

Description, Specifications, and Equipment

DESCRIPTION

The Electric Eel Model RF Drain Cleaning machine is a professional quality sewer and drain cleaning piece of equipment. This machine is specifically designed for cleaning 3" to 6" drain lines up to 100 feet in length and features a two-way auto cable feed for ease of operation. A cable guide spring also keeps hands off rotating cable near the machine.

STANDARD FEATURES

1. Cable available in 5/8" or 3/4" diameter.
2. Snap-Lock tool connectors hold tools firmly in place.
3. Automatic cable feeder that advances and retrieves cable with the push of a lever.
4. Cable guide spring attached to feeder to ensure operator does not handle rotating cable.
5. Power cord is wrapped around conveniently placed brackets for safe, problem-free operation.

6. Easy-to-use foot-operated switch allows the use of both hands when working with cable guide spring and feeder.
7. Ground Fault Circuit Interrupter (GFCI) safety feature comes standard with 20 foot power cord.
8. Heavy duty 1 1/4" durable tubular frame provides stability and balance while in operation.
9. Impact-resistant plastic belt-guard for additional operator safety.
10. Rugged 1/3 H.P. motor delivers optimum cleaning power.

SPECIFICATIONS

- **Cage Capacity:** 100 ft. of 5/8" or 3/4" diameter cable
- **Line Capacity:** 3" – 6" diameter lines up to 100 ft.
- **Weight:** Machine only – 115 lbs. Machine with cable – 210 lbs.
- **Frame:** 1 1/4" open spaced welded steel tubing
- **Motor:** 1/3 H.P. capacitor start motor
- **Auto Cable Feed:** Advances and retrieves cable
- **Controls:** Air foot actuator and 20 ft. cord assembly with built-in Ground Fault Circuit Interrupter (GFCI)
- **Tires:** 10" semi-pneumatic

STANDARD EQUIPMENT

Electric Eel Model RF comes complete with:

- RF unit with auto cable feeder
- Cable guide spring
- 100 ft. of 5/8" or 3/4" Tri-Max Cable
- Set of 4 cleaning tools including:
 - A-1DC starting drill
 - U-3H grease tool
 - HDD-3S root saw
 - ST-1 retriever tool
- 1-FLSC1SC2 flexible leader
- SC-18 spanner wrench
- Pair of **HEAVY** leather gloves
- Tool bag to hold cleaning tools

SAFETY INSTRUCTIONS

The following safety rules for operating Electric Eel's Sewer and Drain Cleaning equipment **MUST** be read carefully before operating this machine.



To prevent serious injuries including:

- Shock, electrocution or burns due to improper grounding.
- Serious injuries to body, limbs or hands and feet due to cables that twist, kink and break.
- Eye injuries caused by loose cable, thrown debris or splashed water.

READ SAFETY INFORMATION THOROUGHLY!

GENERAL SAFETY



TO PREVENT SERIOUS BODILY INJURY:

1. **ALWAYS** wear **HEAVY** leather gloves and safety glasses when operating equipment.
2. Place machine cable guide spring at pipe opening. **NEVER** have exposed cable.
3. **DO NOT** wear loose clothing or jewelry while operating this machine.
4. Use foot switch to operate machine while keeping good

footing and balance at all times.

DO NOT OVERREACH.

5. Machine, foot actuator and cable should be operated by one person only. Additional personnel in the working area should observe all safety instructions.
6. **ALWAYS** keep all guards in place during operation.
7. **ALWAYS** wear rubber-soled non-slip shoes.
8. **ALWAYS** avoid direct contact of skin, facial area and especially eyes with drain water. Chemical compounds used in drains can result in serious burns and other injuries.
9. Replace fittings, cables and any rotating parts as soon as they become visibly worn. Replace any cables which become fractured, bent, kinked, or any other damage occurs.
10. **NEVER** attempt to service equipment beyond the recommendations of the operating instructions. All other servicing should be referred to qualified service personnel.
11. To maintain safe operation, use only identical replacement parts and cables from Electric Eel.
12. **ALWAYS** keep clear of rotating cages/drums, shafts, pulleys, belts, or other rotating parts.

GENERAL SAFETY - ELECTRICAL



DANGER



TO PREVENT SERIOUS BODILY INJURY AND TO AVOID DANGER FROM ELECTRICAL SHOCK:

1. **ALWAYS** use a Ground Fault Circuit Interrupter (GFCI) with a properly grounded outlet for all electrical cords, connections, and parts as installed by factory and **DO NOT** make any alterations.
2. **NEVER** use machine in damp or wet conditions.
3. **NEVER** expose machine to rain.
4. **THE USER SHOULD NEVER ATTEMPT TO SERVICE THE ELECTRICAL COMPONENTS.** For safety reasons, all electrical replacement components should be installed by a qualified electrician.
5. **ALWAYS disconnect the power cord** from the electrical source before making any adjustments or changes to power units.
6. If an extension cord is used, the power source **MUST** be equipped with a Ground Fault Circuit Interrupter (GFCI) and properly grounded.

7. Only use 14/3 or larger three-wire extension cords with three-prong grounding plugs and three-pole receptacles.
8. When using an extension cord outdoors, only use those intended for outdoor use. (Indicated on cord by suffix "W-A" after cord type.)

THE GROUND FAULT CIRCUIT INTERRUPTER (GFCI)

This machine is equipped with a Ground Fault Circuit Interrupter (GFCI) which is designed to prevent a serious electrical shock. This device should be tested on the jobsite before putting the machine into operation as follows:

1. To ensure protection against electric shock, test the device before each use. When test button is pushed in, the indicator light should go off. Reactivate the device by pushing the reset button in. If the indicator light goes on, the device is ready for use. **DO NOT** use the device if the indicator light does not go on when reset or if the indicator light remains on, when the test button is pushed in.
2. This device does not guard against electric shock resulting from defects or faults in any wiring supplying power to this device, or from contact with both circuit conductors.

GENERAL SAFETY-ROTATING CABLES AND EQUIPMENT



DANGER



TO PREVENT SERIOUS BODILY INJURY AND TO AVOID DANGER FROM ROTATING CABLES AND EQUIPMENT:

1. **USE CAUTION AT ALL TIMES.** Cable can twist or kink and cause serious injury. Fingers or other body parts can be caught in rotating parts.
2. **NEVER handle the rotating cable.**
3. **NEVER handle any cable under tension. Relieve all tension build up before attempting to handle cable.**
4. **NEVER operate machine without cable guide spring in place.**
5. Use feeder to advance or retract cable with motor switch in **FORWARD** position for **ALL** cleaning operations.
6. **DO NOT continue to operate machine when cleaning tool becomes stuck in obstruction. Excess torque on a cable could cause it to fracture.** (Refer to operating instructions to free cleaning tool.)

7. **NEVER** force a tool and cable into a pipeline blockage. This may overload the cable or tool and cause it to fracture.
8. **ALWAYS** wear **HEAVY** leather gloves and safety glasses when operating machine.
9. Use correct tool for the job or application. Check the tool listing for the correct tool and line size.
10. To maintain safe and efficient operation, thoroughly clean all cables with water after use. Acids in the drain and sewer lines attack and deteriorate the metal of the cables and tools. Deterioration will cause weakness in cable and tools and result in fracture or breakage. A light coating of oil applied to the cable before storing will help prevent rusting and premature failure.
11. Replace all cables and tools that become deteriorated, worn, kinked, bent, or any other damage that occurs.

MACHINE SET-UP



DANGER



TO PREVENT SERIOUS BODILY INJURY:

NEVER USE ANY CABLE IN THIS MACHINE OTHER THAN ELECTRIC EEL 3/4" OR 5/8" DIAMETER CABLE.

DISCONNECT POWER CORD BEFORE ANY SET UP OR MAINTENANCE IS ATTEMPTED.

This machine comes completely assembled except for the cable guide spring. Simply connect cable guide spring to feeder with snap pin. (See Figure #1)

Figure 1

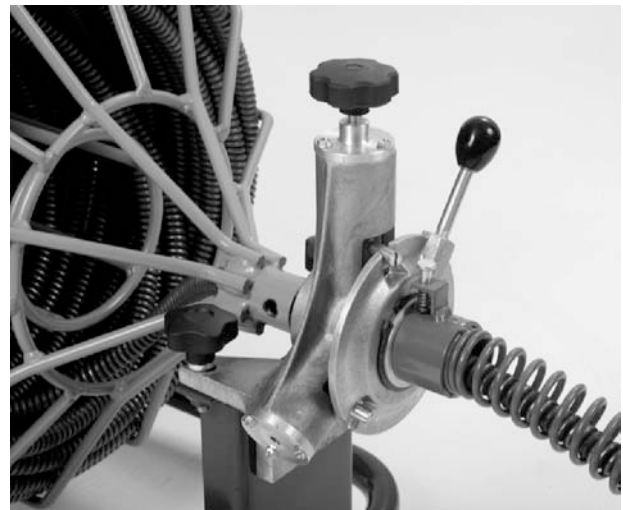

TOOL SELECTION

It is important to choose the proper cleaning tool for each cleaning application. See the tools outlined below.

Standard Tools Included with the Model RF Kit:

1. **SC-18** Spanner Wrench
2. **ST-1** Retriever Tool
3. **U3H** Grease Tool
4. **HDD-3S** Root Saw
5. **A-1DC** Starting Drill Tool
6. **1-FLSC1SC2** Flexible Leader for Negotiating P-Traps

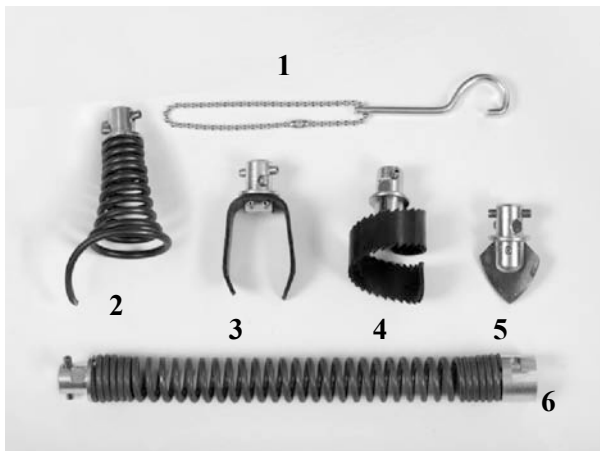

OPERATING INSTRUCTIONS



OPERATOR MUST BE THOROUGHLY FAMILIAR WITH ALL SAFETY INSTRUCTIONS BEFORE OPERATING EQUIPMENT.

FOR AUTOMATIC CABLE FEEDER

1. **WITH POWER OFF**, attach a small spear-type cleaning tool to the end of the cable. This tool will enable you to bore a starter hole in the obstruction, allowing backed-up water to drain.

NOTE: The flexible leader should be used with the A-1DC Starting Tool when negotiating P-Traps or severe bends in the line.

2. Place machine cable guide spring at pipe opening. **NEVER** have exposed cable.
3. Position foot actuator for easy operator accessibility.
4. Make sure switch is in **FORWARD** position. Run machine in **FORWARD** at all times during cleaning operation.
5. Place one **HEAVY** leather gloved hand on the cable guide spring to control cable as it rotates inside; and use other hand to work the feeder control lever.

DANGER: Operator must keep one **HEAVY** leather gloved hand on cable guide spring at all times during operation.

6. **WITH POWER ON**, in order to feed cable, the operator must move the feeder control lever from **NEUTRAL** (the position midway between FORWARD and REVERSE) to the **FORWARD** position, while depressing the foot actuator. (See Figure #2 for **FORWARD** feeder position)

Figure 2



NOTE: The speed at which the cable is fed initially can be controlled by moving the control lever toward **FORWARD** to increase speed and moving back toward **NEUTRAL** to slow speed.

NOTE: If the feeder control lever is initially put in **FORWARD** but the cable is not advancing, then turn the cable tension knob in a clockwise direction until the cable begins to advance. (See Figure #3)

DO NOT over-tighten cable tension knob as it may damage feeder bearings.

Figure 3



7. Continue to automatically feed cable until obstruction is met. When cable begins to drag or rotation becomes difficult, move the lever to the **NEUTRAL** position and allow tool to cut away at the obstruction. (See Figure #4 for **NEUTRAL** feeder position)

Figure 4



DANGER: **NEVER** force the cable or tool into the obstruction. Choose the proper feeding speed in order to give a smooth cutting action.

8. If tool becomes hung up in the obstruction, move control lever to the **REVERSE** position to back out tool. (See Figure #5)

Figure 5



9. After tool has been removed from obstruction, move control lever back to the **FORWARD** position and continue to work through obstruction.
10. To retrieve cable from line, move control lever to the **REVERSE** position (while continuing to operate cage in forward rotation) and cable will back out of line and feed into cage.

NOTE: It is recommended to use a continuous flush of water to clean tool, cable and sewer line as cable is retrieved.

11. When tool is close to cleanout opening, return Control Lever to **NEUTRAL** position, place switch in **OFF** position, release foot actuator and allow machine to come to a complete stop.
DISCONNECT POWER CORD.
12. Pull remaining cable and tool from drain line and hand-feed cable back into machine.

MAIN SEWER OR SEPTIC TANK OVERUN

Operator should determine the approximate distance from cleanout opening to the main sewer or septic tank. **Overrunning cable into these areas can cause cables to twist or knot-up preventing their retrieval.**

MAINTENANCE

Maintenance on the RF machine should be minimal for the life expectancy of the machine. The cable cage is equipped with bearings which do not need to be lubricated, but an occasional lubrication with oil to the machine shaft will help in removal of cable cage and will not harm the bearings.

A light coating of oil applied to the cable before storing will help prevent rusting and premature failure. Greasing all three (3) grease Zerks (fittings) on feeder before each use is recommended. Disassemble and clean complete feeder twice yearly.

CABLE INSTALLATION

DANGER: Exercise caution when removing cables from the package. Wound cables are under tension and may spring apart in a dangerous manner and cause injury.

1. **Disconnect power cord** before any set up or maintenance is attempted.
2. Unpack cable and uncoil by laying it out flat in an open area.
3. Turn cable tension knob counterclockwise to allow cable to be inserted through the feeder and into the cage. (See Figure #6)

Figure 6

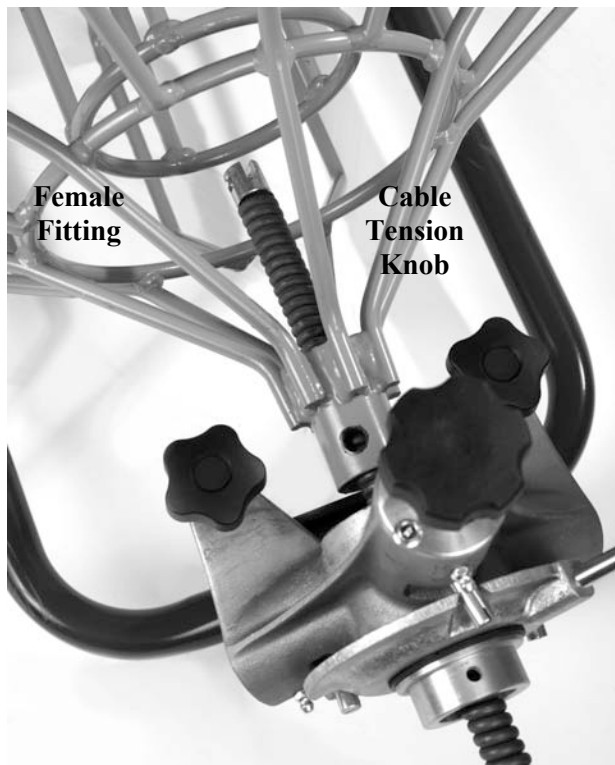

4. Bring cable end out the side of the cage and attach cable anchor. (See Figures #7 and #8)

Figure 7



Figure 8

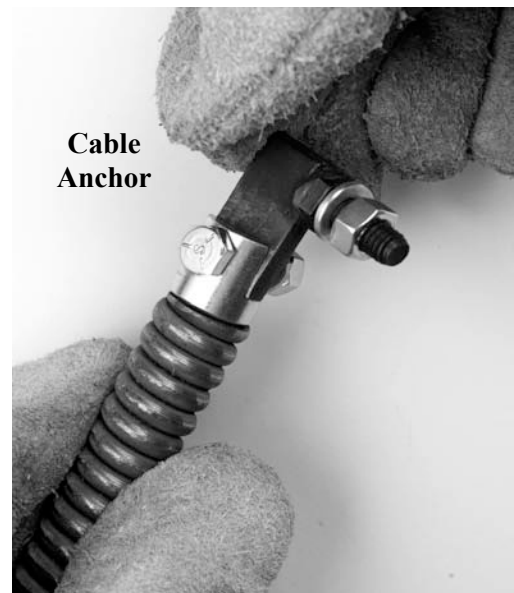

5. Bring cable back into cage, laying cable counterclockwise, and attach cable anchor to back of cage through mounting hole.
(See Figure #9)

Figure 9



6. Attach nut to cable anchor on back side of cage. (See Figure #10)

Figure 10



7. Plug machine in. Motor should be in **FWD** position.
8. To allow cable to feed into cage, place auto cable feeder in **REV** position and depress foot pedal.

CABLE CAGE REMOVAL

1. **Disconnect power cord** before any set up or maintenance is attempted.
2. Remove cable guide spring by pulling retaining pin upward and releasing the spring from the feeder.
3. Remove SP-30 tool adapter with 1/4" punch to drive roll pin out.
4. Remove auto cable feeder by unscrewing both feeder anchoring knobs in a counterclockwise direction on either side of the feeder, allowing the feeder to slide forward. (See Figure #11)

Figure 11



5. Remove belt guard by unscrewing the thumb screw knob on top of belt guard in a counterclockwise direction. (See Figure #12)

Figure 12



6. Push down on top of motor to relieve tension and remove drive belt from pulley. (See Figure #13)

Figure 13



7. Remove retaining clip from front of shaft. (See Figure #14)

Figure 14



8. Remove retaining clip on back side of frame. (See Figure #15)

Figure 15



9. Remove shaft out of the back of the machine to allow cage to be removed. (See Figure #16)

Figure 16



10. Reverse the above procedure to reinstall the cable cage.

REMOVING THE HANDLE

The handle can be removed from the machine for compact storage of unit or for work in crawl spaces by backing off the two thumb screws. When replacing the handle, be sure the thumb screw tips engage in the corresponding holes in the handle.

CABLE REPAIR FITTINGS

The following fittings are used for cable repair.

1. **SP-30** Tool Adapter
2. **SP-32** Female Fitting 3/4" Cable
SJ-32 Female Fitting 5/8" Cable
3. **SP-31** Male Fitting 3/4" Cable
SJ-31 Male Fitting 5/8" Cable
4. **RP 1434** Roll Pin 3/4" Cable
RP 1458 Roll Pin 5/8" Cable

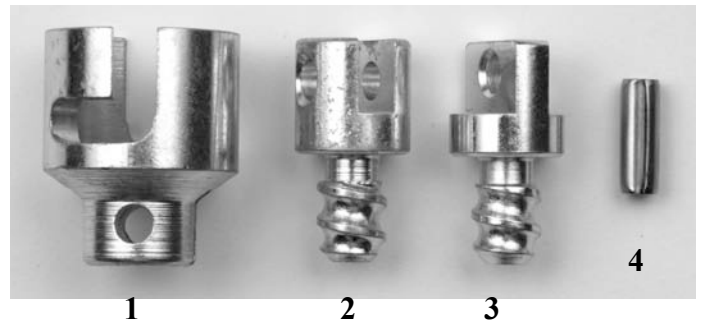

WARNING: This product can expose you to chemicals including lead, which is known to the State of California to cause cancer and birth defects or other reproductive harm. For more information, go to www.P65Warnings.ca.gov.

MODEL RF DRAIN CLEANING MACHINE

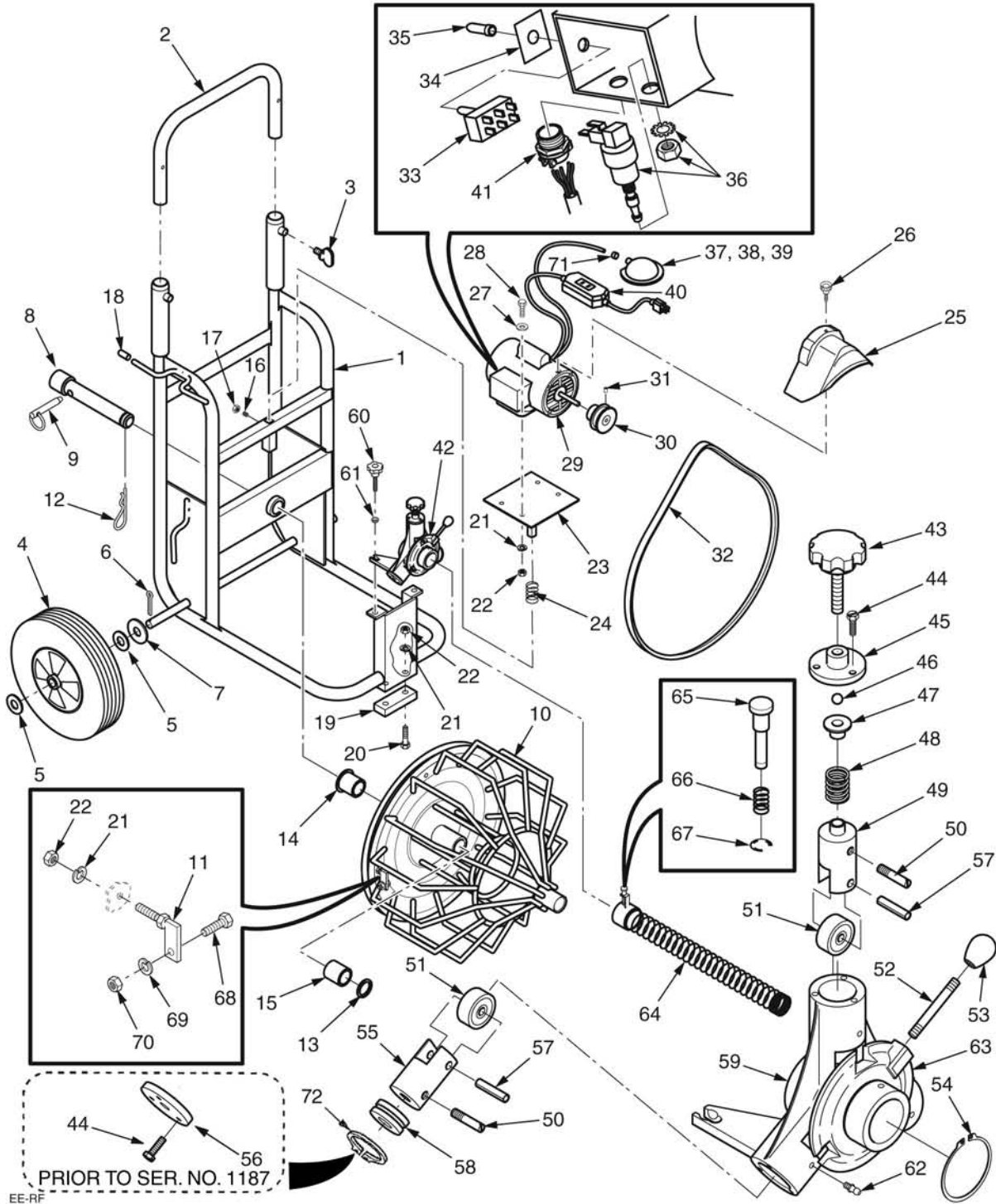

MODEL RF DRAIN CLEANING MACHINE

ITEM NUMBER	PART NUMBER	DESCRIPTION	AMT
1	RF1	Frame.	1
2	RF2	Handle	1
3	DL-4	Thumb Screw	2
4	R-W10	10" dia. x 5/8" Wheel	2
5	WA58P	Washer.	4
6	CP532114	Cotter Pin	2
7	D12	Wheel Spacer.	2
8	RF3	Cage Axle	1
9	RF3RP	Axle Retaining Pin	1
10	R-20*	Cable Cage	1
11	R-14	Cable Anchor.	1
12	RFHPC	Cage Hairpin Clip	1
13	RF4	Cage Spacer.	1
14	OBSF324016	Rear Cage Bushing	1
15	OBSS324216	Front Cage Bushing.	1
16	SS5162458DP	5/16- x 5/8 Set Screw	1
17	NU51624FHP	5/16-24 Hex Nut	1
18	DL6CAP	Cord Hook Cap	3
19	D47	Rubber Pad	1
20	CSHH516181	5/16-18 x 1 1/4 Cap Screw	2
21	LW516	5/16" Lockwasher	6
22	NU51618FHP	5/16" Hex Nut	6
23	EE-23	Motor Mount.	1
24	EE-9	Motor Tension Spring	1
25	R-24	Belt Guard	1
26	TS14	Thumb Screw 1/4".	1
27	WA516S	5/16" Washer.	4
28	CSHH516181	5/16-18 x 1 Cap Screw	4
29	RM-1/3	Motor 1/3 HP.	1
30	N-8	Motor Pulley	1
31	SS51618516	5/16-18 x 5/16" Set Screw.	
32	A-48	V-belt.	1
33	SW-FO	Forward/Reverse Switch	1
34	SW-FOP	Forward/Reverse Switch Plate	1
35	SW-BOOT	Forward/Reverse Switch Boot.	1
36	TBS3218	Air Activated On/Off Switch.	1
37	FP-1A**	Foot Pedal and Hose Assy.	1
38	FP-1	Foot Pedal	1
39	FP-2	Air Hose	1
40	GFCI	Ground Fault Circuit Interrupter	1
41	TSC12	Two Screw Connector	1
42	DE-23A***	Feeder Assembly	1
43	DE-7	Tension Handle w/Shaft	1
44	MSHH102434	10-24 x 3/4" Cap Screw	9

MODEL RF DRAIN CLEANING MACHINE

ITEM NUMBER	PART NUMBER	DESCRIPTION	AMT
45	DE-5	Top Feeder Head Cap	1
46	BB38	3/8" Ball Bearing	1
47	DE-8	Ball Bearing Retainer	1
48	DE-9	Tension Spring.	1
49	DE-3	Top Feeder Insert.	1
50	DE-12	Feeder Control Finger	3
	DE-25ASET	Feeder Bearing Set	1
51	DE-25A	Feeder Bearing	3
52	DE-13	Control Lever	1
53	DE-14	Control Lever Knob.	1
54	RR-237	Retaining Ring	1
55	DE-22*****	Lower Feeder Insert.	2
56	DE-6	Lower Feeder Head Cap	2
57	RP516138	5/16-18 x 1 3/8" Roll Pin	3
58	DE-11	Feeder Insert Bearing	2
59	DE-23*****	Feeder Head Body.	1
60	DE-15	Feeder Anchor Bolts	2
61	DE-16	Feeder Anchor Washer	2
62	GZ1428S	Grease Zerk 1/4-28 Short	3
63	DE-2	Feeder Face Plate	1
64	DE-18A****	Cable Guide Spring Assy	1
65	DE-19	Guide Spring Lock Pin	1
66	DE-20	Guide Lock Pin Spring	1
67	RR25	Retaining Ring	1
68	CSHH14201	Cap Screw Hex Head 1/4-20 x 1	1
69	LW14	Lockwasher 1/4	1
70	NU1420FHP	1/4"-20 Hex Nut	1
71	FP-3	Hose Clamp.	2
72	RR-137*****	Retaining Ring	1

- * Includes Items 10 through 15, 21, 22, 68, 69, and 70
- ** Includes Items 37, 38, 39, and 71
- *** Includes Items 42, 43 through 63. Prior to Serial No. 1187, Item 42 Part No. is DE-21A
- **** Includes Items 64 through 67
- ***** Prior to Serial No. 1187, Item No. 55 Part No. is DE-4
- ***** Prior to Serial No. 1187, Item No. 59 Part No. is DE-21
- ***** Prior to Serial No. 1187, Item No. 44 and 56 were used