

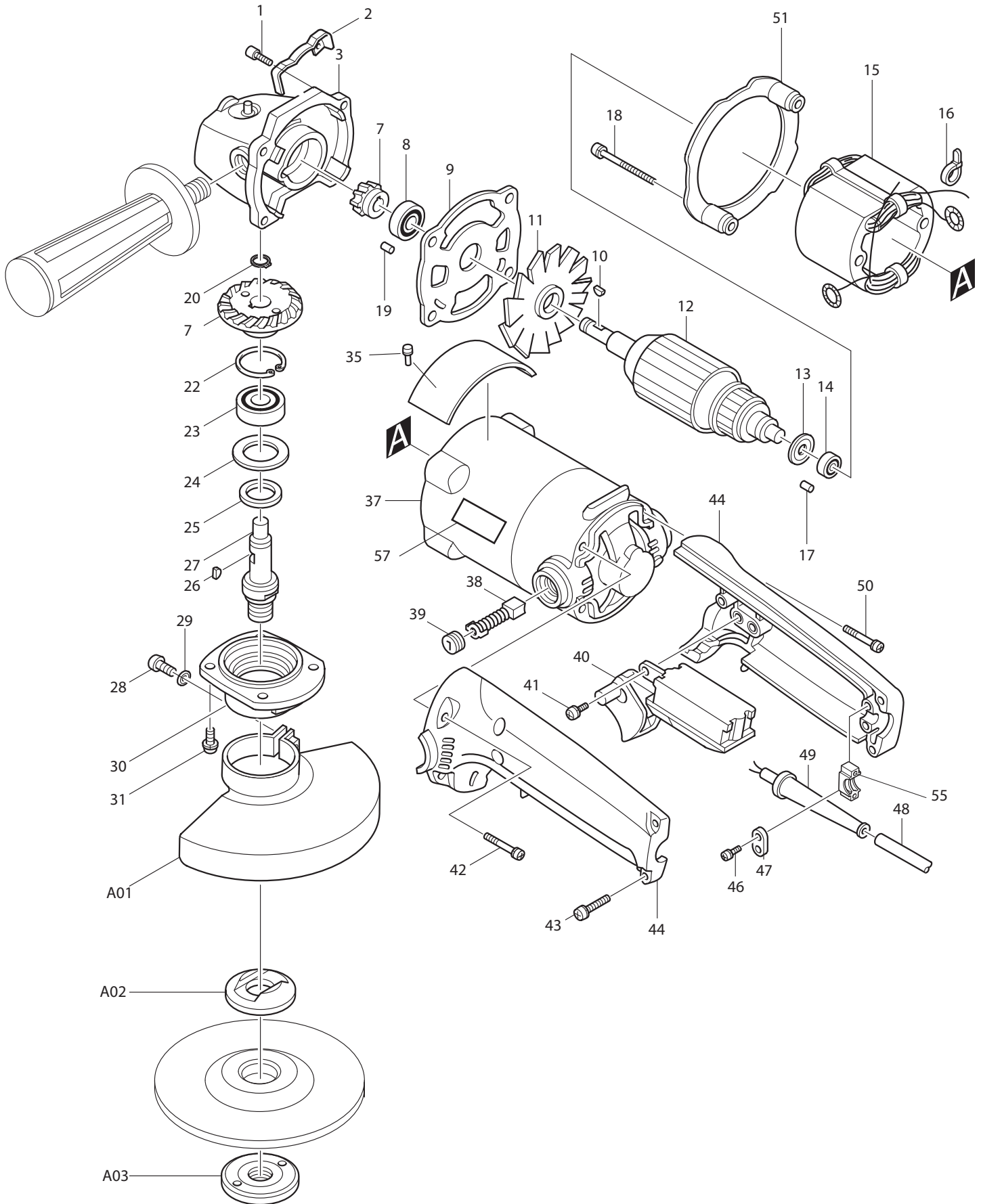

11 - 2010
9005BY
5" DISC GRINDER, LOCK OFF



Item	Type	Sub	Parts No.	Description	Qty	Unit
001	6		266459-3	TAPPING SCREW 5X25	4	PC.
003	3		144196-8	* GEAR HOUSING COMPLETE	1	PC.
		INC.	212005-0	* NEEDLE BEARING 810	1	PC.
		INC.	231464-9	* COMPRESSION SPRING 5	1	PC.
		INC.	256616-1	* PIN 5	1	PC.
		INC.	343312-1	* CUP	1	PC.
		INC.		* Item No. 19		
007	1		181737-9	SPIRAL BEVEL GEAR SET	1	SET
	2		187603-8	SPIRAL BEVEL GEAR SET	1	SET
008	2		211088-7	BALL BEARING 6000DDW	1	PC.
009			341681-4	PLATE	1	PC.
010			254002-0	WOODRUFF KEY 3	1	PC.
011			241517-6	FAN 70	1	PC.
012			516091-6	ARMATURE ASS'Y 115V	1	PC.
		INC.		Item No. 11,13,14		
013			681613-2	INSULATION WASHER	1	PC.
014	2		210005-4	BALL BEARING 608DDW	1	PC.
015	3		520085-5	FIELD ASS'Y 115V	1	PC.
		INC.	654019-7	RING TERMINAL	2	PC.
		INC.	654555-3	CONNECTOR 34130	2	PC.
016			687010-0	BAND	1	PC.
017			263014-2	RUBBER PIN 4	1	PC.
018	6		266352-1	TAPPING SCREW 5X65	2	PC.
019			263002-9	RUBBER PIN 4	1	PC.
020			961052-5	RETAINING RING S-12	1	PC.
022			962151-6	RETAINING RING R-32	1	PC.
023	2		211129-9	BALL BEARING 6201DDW	1	PC.
024	2		267126-3	FLAT WASHER 22	1	PC.
025			443051-4	FELT RING 20	1	PC.
026			254002-0	WOODRUFF KEY 3	1	PC.
027	1		321336-7	* SPINDLE	1	PC.
	2		326791-8	* SPINDLE A	1	PC.
028	1		251259-4	* + PAN HEAD SCREW M5X16	1	PC.
	2		265180-1	* PAN HEAD SCREW M5X16	1	PC.
029			942101-7	SPRING WASHER (OLD)	1	PC.
030	1		315282-4	* BEARING BOX	1	PC.
	2		319462-4	* BEARING BOX	1	PC.
031	3		266148-0	HEX. SOCKET HEAD BOLT M4X14	4	PC.
036	2		869621-5	NAME PLATE 9005BY - RPM 12000/ min	1	PC.
037	5		153548-2	MOTOR HOUSING COMPLETE	1	PC.
		INC.	810341-4	CAUTION LABEL (Added)	1	PC.
		INC.		Item No. 17		
037		INC.	643603-3	* BRUSH HOLDER 6-10 (Old 643609-1)	2	PC.
038	2		194982-7	CARBON BRUSH CB-124 2PC/SET (W/ ORIGIN)	1	SET
	Opt.		194975-4	AUTO CUT-OFF CARBON BRUSH CB-105 (2PCS/SET)	1	SET
039			643600-9	BRUSH HOLDER CAP 6-10	2	PC.
040			651142-9	SWITCH LOCK-OFF AC/DC, TRIGGER	1	PC.
041			911113-1	P.H.SCREW M4X10 (OLD)	1	PC.
042	6		266459-3	TAPPING SCREW 5X25	2	PC.
043			911143-2	PAN HEAD SCREW M4X22	3	PC.
044	6		187581-2	* HANDLE SET	1	SET
		INC.	421565-3	* SPONGE SHEET	1	PC.
	7		183E60-8	* HANDLE SET	1	SET
		INC.	421565-3	* SPONGE SHEET	1	PC.
046	2		265995-6	TAPPING SCREW 4X18	2	PC.

Item	Type	Sub	Parts No.	Description	Qty	Unit
		3	265A48-7	TAPPING SCREW M4X18	2	PC.
047			687063-9	CORD CLAMP (STRAIN RELIEF)	1	PC.
048			664064-4	CORD W/PLUG 2P-18-2.5M, SJ	1	PC.
049	2		682572-3	CORD GUARD 8	1	PC.
050	6		266459-3	TAPPING SCREW 5X25	2	PC.
051			411876-4	BAFFLE PLATE	1	PC.
055			687051-6	CLAMP BASE	1	PC.
056			261039-0	URETHANE WASHER 14	3	PC.
	Opt		191728-2	URETHANE WASHER 14, 3PC/SET (OPTION) (MAKE EASY REMOVAL OF WIRE CUP BRUSH)	1	SET
057	1		819001-5	MAKITA LABEL, ENG	1	PC.
D01			652014-1	P.H.SCREW M4X8 (F/ SWITCH)	4	PC.
D02	2		654113-5	SOLDERLESS EYE TERMINAL 1.25-M4 (F/ SWITCH)	4	PC.
E04			654532-5	TERMINAL BLOCK 1P	1	PC.
E05			689054-6	RING TERMINAL RETAINER 13 (Added)	2	PC.

ACCESSORIES

- See catalogue or visit www.makita.ca for more accessories information -

A01	3		135549-2	* WHEEL COVER ASS'Y F/5"	1	PC.
		INC.		* Item No. 28		
	4		123099-9	* WHEEL COVER ASS'Y F/5" (H:46MM)	1	PC.
		INC.		* Item No. 28		
		INC.	213009-5	* O RING 4		
A02	1		224361-6	INNER FLANGE 82	1	PC.
	3		224378-9	INNER FLANGE 45	1	PC.
	4		224399-1	INNER FLANGE 45	1	PC.
A03	1		224509-0	LOCK NUT 5/8-40	1	PC.
	3		224568-4	LOCK NUT 5/8-45	1	PC.
A04			152492-0	GRIP 36 COMPLETE	1	PC.
A05	2		741407-B	5" DEPRESSED CENTER WHEEL A24P	1	PC.
	3		D-20797	5" ABRASIVE DEPRESSED CENTRE WHEEL A24R	1	PC.
	4		A-95962-25	5" D.C.G.W WA36N 25/PK	1	SET
A06			782412-6	LOCK NUT WRENCH 28	1	PC.
A07			743015-1	RUBBER PAD F/ 5" (F/ ABRASIVE DISC)	1	PC.
A09			193048-0	SANDING LOCK NUT 5/8-48	1	PC.
A13	2		123850-7	CUT-OFF WHEEL GUARD ASSY F/5"	1	PC.
		INC.	-----	M5X16 PAN HEAD SCREW	1	PC.
	3		122911-0	* CUT-OFF WHEEL GUARD F/5"	1	PC.
A14	1		196587-9	* DUST COLLECTION COVER 5" - Parts Breakdown #196587-9	1	PC.
	2		196575-6	* DUST COLLECTION COVER 4-1/2-5" - See Parts Breakdown #196575-6	1	PC.
	3		1911K3-9	DUST COLLECTION COVER F/ 4-1/2" - 5" DMND CUP WHEEL	1	PC.
A15	2		196845-3	* DUST COLLECTION COVER 5" DMND, TUCKPOINT BLADE	1	PC.
A16			B-38532	5" 2IN1 ABRASIVE DISC A36T	1	PC.

SERVICE CHANGE

1. Service Change On Motor Housing Com., Screw

Item No.	Description	MCT prod			MJ prod	MCA Prod
		Type 1	Type 2	Type 3	Type 4	Type 5
1	SCREW 5X25	911241-2 (P.H.)	266041-8 (Tap)		911241-2 (P.H.)	266041-8 (Tap)
18	SCREW 5X65	911290-9 (P.H.)	266029-8 (Tap)		911290-9 (P.H.)	266029-8 (Tap)
37	MOTOR HOUSING	156734-4	153455-9	153548-2	140102-1 (N/A)	153548-2
42	SCREW	911248-8 (P.H.M5X28)	266041-8 (Tap 5X25)		911248-8 (P.H.M5X28)	266041-8 (Tap 5X25)
50	SCREW	911248-8 (P.H.M5X28)	266041-8 (Tap 5X25)		911248-8 (P.H.M5X28)	266041-8 (Tap 5X25)

Above Parts Are Interchangeable As A Set.

2. Service Change On Gear Housing, Tool Rest, Etc.

(T/I# B3707)

Item No.	Description	Type 1	Type 2	Type 3	Type 4
3	GEAR HOUSING	156735-2 (N/L/A)	159710-7		144196-8
2	TOOL REST	341680-6	N/A		
31	SCREW	911121-2 (P.H.M4X14)	266034-5 (Tap 4X16)	266148-0 (Hex Bolt M4X14)	

Above Parts Are Interchangeable As A Set.

3. Service Change On Handle, Strain Relief, Etc.

(T/I# 97189) (T/I# B3707)

Item No.	Description	Type 1	Type 2	Type 3	Type 4	Type 5	Type 6	Type 7
41	P.H. SCREW M4X10	911113-1	N/A					
44	HANDLE (L)	411797-0 (N/L/A)	414709-2 (N/L/A)	414709-2 (N/L/A)	182418-8 SET	182853-0 SET	187581-2 SET	187581-2 SET
52	HANDLE (R)	411798-8 (N/L/A)	4147410-7 (N/L/A)					
-	SPONGE SHEET	N/A	N/A	421565-3 (Component of Item No. 44 & 52)				
46	SCREW M4X18	911131-9 (P.H.)	265941-9 (Tap)		265995-6 (Tap)			
47	STRAIN RELIEF	687002-9	687063-9 (OLD 687052-4)					
55	CLAMP BASE	N/A	687051-6					
D02	TERMINAL	654002-4 (4PC)				654113-5 (4PC)	654113-5 (2PC)	
D03	TERMINAL BLOCK	-----					654532-5	

Above parts Are Interchangeable As A Set.

SEE T/I# 97189 FOR WIRING CHANGES

4. Changes on Wheel cover, etc.

(TI#68249) (TI#B3707)

Item No.	Description	Type 2	Type 3	Type 4
27	Spindle > Spindle A		321336-7	326791-8
28	PH Screw M5X16		251259-4	265180-1
30	Bearing Box		315282-4	319462-4
A01	Wheel Cover Ass'y F/5"	135040-0	135549-2	123099-9
	INC. O Ring 4			213009-5
A02	Inner Flange 82 > 45	224361-6	224378-9	224399-1
A03	Lock Nut 5/8-40 5/8-45	224509-0	224568-4	
A13 Opt.	COW Wheel Cover Assy	122688-7 or 123850-7		122911-0
A14 Opt.	Dust Collection Cover	196587-9		196575-6
A15 Opt.	Dusct Collection Cover F/Diamond & Tuckpoint Blade	192188-1		196845-3

*Component of A01

Above parts are completely interchangeable as a set.

Type 3

Type 4

