

**Series 900® Flushometer**

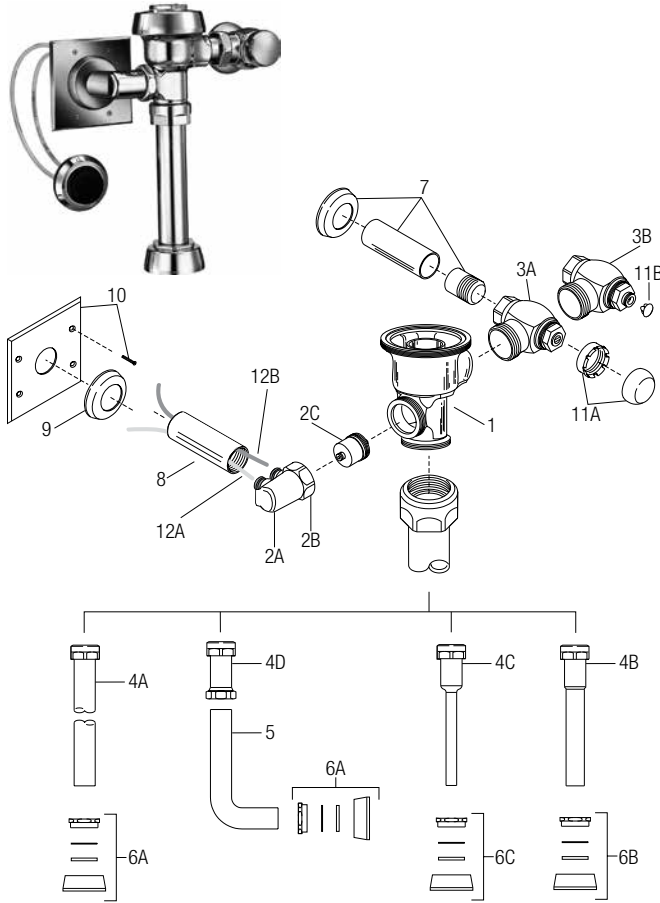

**PARTS LIST FOR SERIES 900® EXPOSED FLUSHOMETER**

Item No.	Code No.	Part No.	Description
1.	<b>0301048</b>	A-143-A	Valve Body
2A.	<b>0318065PK</b>	HY-65	Valve Actuator Housing
2B.	<b>0301082PK</b>	A-6	Housing Nut
2C.	<b>3318001PK</b>	HY-83-A	Actuator Cartridge Assembly
3A.	<b>3308386</b>	H-700-A	Bak-Chek® Control Stop (Royal Valves) for 1" 3308384 for ¾"
3B.	<b>0388065</b>	H-790-A	Bak-Chek® Control Stop (Regal XL Valves) for 1" 0388064 for ¾"
4A.	<b>3893004</b>	V-600-AA	1½" (38 mm) Vacuum Breaker Assembly
4B.	<b>3393006</b>	V-600-AA	1¼" (32 mm) Vacuum Breaker Assembly
4C.	<b>3393004</b>	V-600-AA	¾" (19 mm) Vacuum Breaker Assembly
4D.	<b>0393003</b>	V-600-A	Vacuum Breaker
5.	<b>0396293</b>	F-109	1½" (38 mm) Elbow Flush Connection
6A.	<b>0306146</b>	F-5-AT	1-1/2" (38 mm) Spud Coupling Assembly (Royal Valves)
	<b>0306145</b>	F-56-A	1½" (38 mm) Spud Coupling Assembly (Regal XL Valves)
6B.	<b>0306140</b>	F-5-AU	1¼" (32 mm) Spud Coupling Assembly (Royal Valves)
	<b>0306142</b>	F-55-A	1¼" (32 mm) Spud Coupling Assembly (Regal XL Valves)
6C.	<b>0306125</b>	F-5-AW	¾" (19 mm) Spud Coupling Assembly (Royal Valves)
	<b>0306102</b>	F-54-A	¾" (19 mm) Spud Coupling Assembly (Regal XL Valves)
7.	<b>3308782</b>	H-633-AA	1" (25 mm) Sweat Solder Kit & Cast Wall Flange w/ Set Screw
	<b>3308788</b>	H-636-AA	¾" (19 mm) Sweat Solder Kit & Cast Wall Flange w/ Set Screw
8.	<b>0318064PK</b>	HY-64	6" Chrome Sleeve
9.	‡	F-7	Supply Flange
10.	<b>3318002</b>	HY-112-A	Plate with Screws
11A.	<b>3308772</b>	H-1010-A	Free Spinning Vandal Resistant Stop Cap (Royal Valves)
11B.	<b>5388002</b>	H-528	Vandal Resistant Hole Plug (Regal Valves)
12A.	<b>0318221</b>	HY-146	1/4" (6mm) x 48" (1219 mm) Yellow connecting tube
12B.	<b>0318217</b>	HY-145	1/4" (6mm) x 48" (1219 mm) Blue connecting tube

† Part number varies with valve model variation; consult factory.  
‡ Length varies with valve variation; consult factory.

## Series 900® Flushometer

### PARTS LIST FOR SERIES 900® CONCEALED FLUSHMETER

Item No.	Code No.	Part No.	Description
1.	0301173	A-72	RB Royal® Cover
2.	0301168	A-71	Inside Cover
3.	<b>SEE THE INSIDE PARTS KIT CHART ON NEXT PAGE</b>		
4.	3323182	V-651-A	Vacuum Breaker Repair Kit
5.	0308690	H-550	RB Tailpiece Coupling
6.	0308802	H-551-A	RB Adjustable Tailpiece, 2-1/16" (52 mm)
7A.	5308696	H-553	O-ring – 24 per package
7B.	5308381	H-552	Locking ring – 12 per package
8.	0388010	H-730-A	RB Wheel Handle Bak-Chek® Control Stop
9A.	3308855	H-541-A	1" Wheel Handle Repair Kit for H-730-A Control Stop
9B.	3308858	H-543-A	3/4" Wheel Handle Repair Kit for H-730-A Control Stop
10.	0308919	H-558-A	Wheel Handle
11A.	0208083	H-623	1" RB Bonnet
11B.	0208083	H-623	3/4" RB Bonnet
12.	See page 111	V-500-AA	Royal Vacuum Breaker Flush Connection (specify length and size)
13.	0306619	F-2-AA	1-1/2" (38 mm) RB Couplings (2 each), Friction Rings (2 each), and Rubber Gaskets (2 each)
14.	0206146	F-21	RB Elbow
15.	0306091	F-2-A	1-1/2" (38 mm) RB Coupling and S-21 Flat Rigid Gasket
16.	See pages 111-116	F-100	RB Flared End Flush Connection (specify length)
17.	See pages 111-116	F-15-A	3/4" (19 mm) RB Elbow Flush Connection with Coupling and Rubber Gasket (specify length)
18.	0306054	F-2-A	3/4" (19 mm) RB Coupling, Friction Ring, and Rubber Gasket
19.	0318024	HY-109	RB Valve Actuator Housing (includes fittings)
20A.	0318221	HY-146	1/4" (6 mm) x 48" (1219 mm) Yellow Connecting Tubes (2 required)
20B.	0318217	HY-145	1/4" (6 mm) x 48" (1219 mm) Blue Connecting Tubes (2 required)
21.	0301082	A-6	RB Handle Coupling Nut
22.	3318005	HY-109-A	Actuator Housing Assembly (includes items 21 & 24)
23.	3318001	HY-83-A	Actuator Cartridge Assembly
24.	0337086	DO-22	O-ring for HY-109-A Adapter
25.	<b>SEE SLIP JOINT GASKETS AND RINGS TABLE BELOW</b>		
26.	0301050	A143-A	RB Valve Body

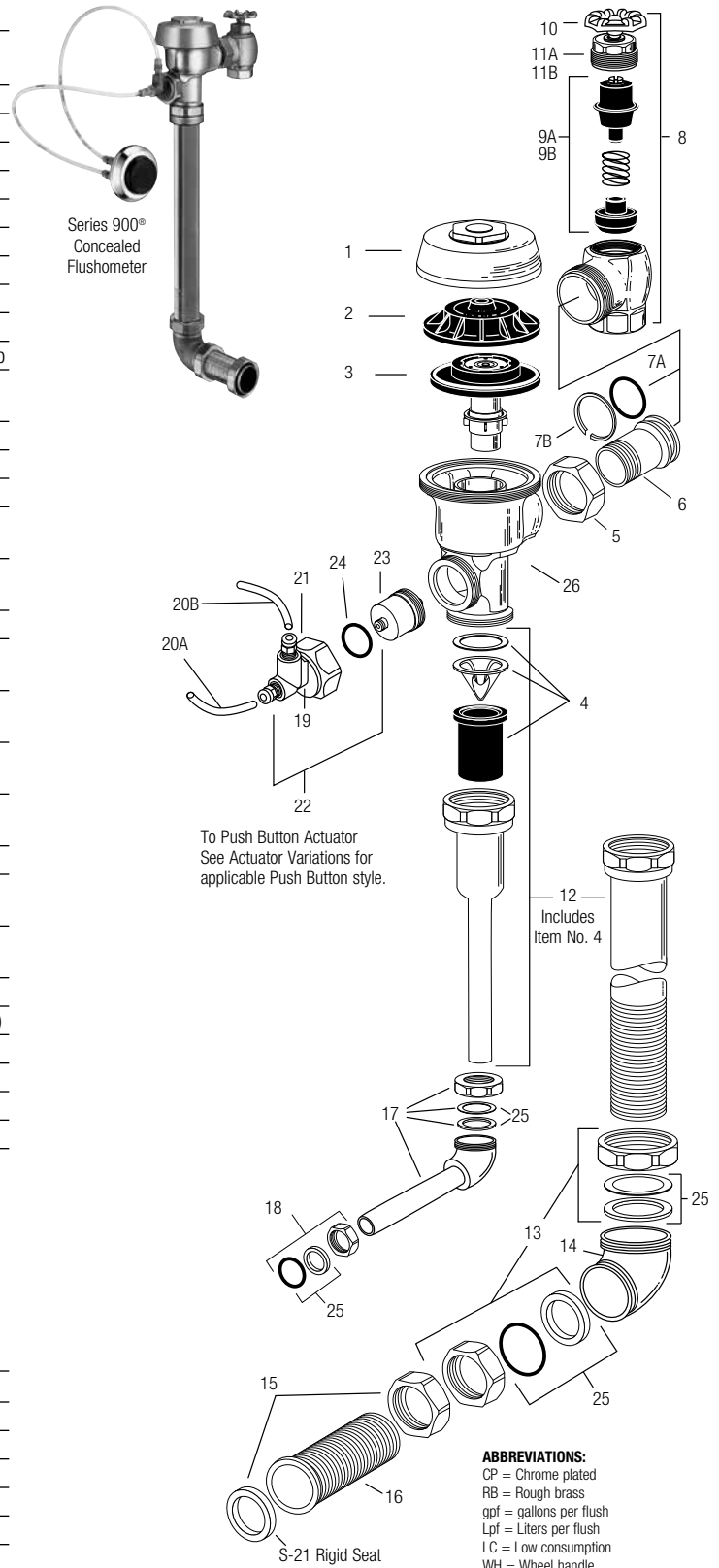

### ITEM 27. SLIP JOINT GASKETS AND RINGS

Size	Code No.	Part No.	Description
1-1/2"	5306058	F-3	Red Friction Ring
	5322001	VBF-5	Black Slip Joint Gasket
	0319086/5319086	S-30	Flexible Seat
	0319079	S-21	Rigid Seat (rubber over brass)
1-1/2" x 1-1/4"	0396062	F-105	Slip Joint Gasket – Rigid
1-1/4"	5306057	F-3	Red Friction Ring
	5322176	VBF-5	Black Slip Joint Gasket
	0307052/5307052	G-21	Rigid Seat (rubber over brass)
	5306056	F-3	Red Friction Ring
1"	5306115	F-5	Black Slip Joint Gasket
	5306055	F-3	Red Friction Ring
3/4"	5306113	F-5	Black Slip Joint Gasket

### TAILPIECES, CONTROL STOPS, PUSH BUTTONS AND FLUSH CONNECTIONS

For additional information on tailpieces, control stops, push buttons and flush connections see Showerheads, Parts and Accessories Tab.

## Series 900® Flushometer

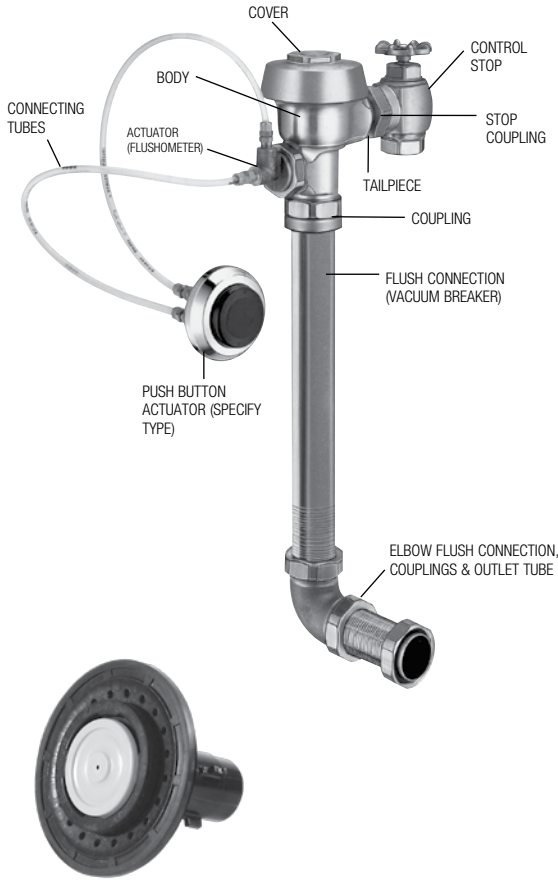

### Regal Flushometer

#### DIAPHRAGM INSIDE PARTS KITS

Code No.	Part No.	Application
3301036	A-36-A	4.5 gpf/17.0 Lpf - Closet
3301037	A-37-A	1.5 gpf/5.7 Lpf - Urinal
3301038	A-38-A	3.5 gpf/13.2 Lpf - Closet
3301041	A-41-A	1.6 gpf/6.0 Lpf - Closet
3301044	A-42-A	1.0 gpf/3.8 Lpf - Urinal
3301081	A-43-A	0.5 gpf/1.9 Lpf - Urinal
3301024	A-44-A	2.4 gpf/9.0 Lpf - Closet
3301045	A-140-A	1.28 gpf/4.8 Lpf - Closet

#### INSIDE PARTS COMPONENTS

Code No.	Part No.	Description
5301058	A-19-AC	Relief Valve, White (Closet) – 12 per pkg.
5301059	A-19-AU	Relief Valve, Black (Urinal) – 12 per pkg.
5301211	A-19-ALC	Relief Valve, Green (Closet/Urinal-LC) – 12 per pkg.
0301143	A-19-AL	Relief Valve, Blue (9 Liter Closet)
5301111	A-15-A	Disc – for all Inside Parts Kits – 12 per pkg.
5301188	A-156-A	Diaphragm – for all Inside Parts Kits – 12 per pkg.
5301236	A-163-A	Guide Assembly 4.5 gpf/17.0 Lpf Closet & 1.5 gpf/5.7 Lpf Urinal – 12 per package
5301032	A-152-A	Guide Assembly 3.5 gpf/13.2 Lpf Closet – 12 per package
5301031	A-151-A	Guide Assembly 1.6 gpf/6.0 Lpf LC Closet – 12 per package
5301155	A-155-A	Guide Assembly 1.0 gpf/3.8 Lpf LC Urinal – 12 per package
5301157	A-157-A	Guide Assembly 0.5 gpf/1.9 Lpf Urinal – 12 per package

### Royal Flushometer

#### ITEM 3. INSIDE PARTS KITS (SEE ILLUSTRATION ON PREVIOUS PAGE)

Code No.	Part No.	Application
3301502	A-1041-A	Low Consumption Water Closets- 1.6 gpf (6.0 Lpf)*
3301501	A-1038-A	Water Saver Water Closets-3.5 gpf (13.2 Lpf)*
3301505	A-1044-A	9 Liter European Water Closets-2.4 gpf (9.0 Lpf)
3301504	A-1043-A	Wash Down Urinals-0.5 gpf (1.9 Lpf)
3301503	A-1042-A	Low Consumption Urinals-1.0 gpf (3.8 Lpf)*
3301500	A-1037-A	Water Saver Urinals-1.5 gpf (5.7 Lpf)*
3301506	A-1045-A	High-Efficiency Water Closets-1.28 gpf (4.8 Lpf)

\* WATER SAVER (3.5 GPF CLOSET AND 1.5 GPF URINAL) AND LOW CONSUMPTION (1.6 GPF CLOSET AND 1.0 GPF URINAL) FIXTURES MUST USE MATCHING GPF (LPF) DIAPHRAGM KITS; USING A SMALLER GPF (LPF) KIT IN FIXTURES NOT INTENDED FOR LESS VOLUME WILL RESULT IN INADEQUATE DILUTION IN URINALS AND IMPROPER EVACUATION IN CLOSETS.

#### HYDRAULIC INSIDE PARTS REPAIR KITS

Code No.	Part No.	Description
3318011	HY-1101-A	Hydraulic Royal 1.6C
3318012	HY-1102-A	Hydraulic Royal 3.5C
3318013	HY-1103-A	Hydraulic Royal 2.4C
3318014	HY-1106-A	Hydraulic Royal 0.5U
3318015	HY-1107-A	Hydraulic Royal 1.0U
3318016	HY-1108-A	Hydraulic Royal 1.5U

Comes with: Diaphragm, Actuator Cartridge Assembly, Tailpiece O-ring and Vacuum Breaker Assembly



### Sloan Flushometer

#### DIAPHRAGM INSIDE PARTS KITS

Includes Relief Valve and Diaphragm Assembly

Code No.	Part No.	Application
3378041	SV-41-A	1.6 gpf/6.0 Lpf - Closet
3378038	SV-38-A	3.5 gpf/13.2 Lpf - Closet
3378044	SV-44-A	2.4 gpf/9.0 Lpf - Closet
3378037	SV-37-A	1.5 gpf/5.7 Lpf - Urinal
3378042	SV-42-A	1.0 gpf/3.8 Lpf - Urinal
3378043	SV-43-A	0.5 gpf/1.9 Lpf - Urinal
3378047	SV-47-A	1.28 gpf/4.8 Lpf - Closet

#### INSIDE COMPONENTS

Code No.	Part No.	Description
5301211	A-19-ALC	Relief Valve, Green (Closet/Urinal-LC) – 12 per package
5301058	A-19-AC	Relief Valve, White (Closet) – 12 per package
0301143	A-19-AL	Relief Valve, Blue (9 Liter Closet)
5301059	A-19-AU	Relief Valve, Black (Urinal) – 12 per package

## Series 900® Flushometer

### HY-49-A (0318049) METAL PARTITION PUSH BUTTON

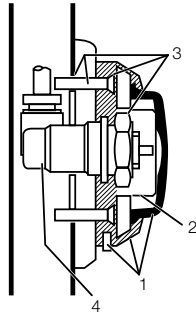

Item No.	Code No.	Part No.	Description
1.	<b>0318007</b>	HY-1000-A	Push Button Kit – includes Push Button, Flange, Spring & Set Screw
2.	<b>0318004</b>	HY-3	Spring
3.	<b>0318010</b>	HY-1003-A	Mounting Flange Kit – includes Mounting Flange, Mounting Nut, Screws (2) & Tinnerman Nuts (2)
4.	<b>0318123</b>	HY-71-A	Actuator Assembly

NOTE: Includes HY-32-A cartridge (shown at right)  
NOTE: Maximum distance from button to valve is 20' (longer tubing required)  
NOTE: HY-30 84" longer tubing (0318094)

### HY-72-A (0318072) SIDE WALL PUSH BUTTON

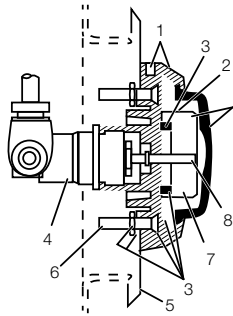

Item No.	Code No.	Part No.	Description
1.	<b>0318007</b>	HY-1000-A	Push Button Kit – includes Push Button, Flange, Spring & Set Screw
2.	<b>0318004</b>	HY-3	Spring
3.	<b>0318008</b>	HY-1001-A	Mounting Flange Kit – includes Mounting Flange, Mounting Nut, Screws (2), Nuts (2) & Washers (2)
4.	<b>0318123</b>	HY-71-A	Actuator Assembly
5.	<b>0318041</b>	HY-40	Plate
6.	<b>0305173</b>	EL-173	Screws (4)
7.	<b>0318073</b>	HY-73	Extension Adapter
8.	<b>0318074</b>	HY-74	Extension Stem

NOTE: Includes HY-32-A cartridge (shown at right)  
NOTE: Maximum distance from button to valve is 20' (longer tubing required)  
NOTE: HY-30 84" longer tubing (0318094)

### HY-108-A (0318119) PENAL WARE METAL PUSH BUTTON

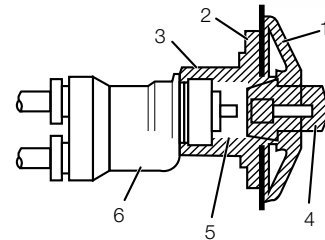

Item No.	Code No.	Part No.	Description
1.	<b>0318116</b>	HY-91	Flange
2.	<b>0318111</b>	HY-94	Mounting Washer
3.	<b>0318112</b>	HY-93	Mounting Nut
4.	<b>0318115</b>	HY-86-A	Push Button Assembly
5.	<b>0305134</b>	EL-109	Spring
6.	<b>0318078</b>	HY-50-A	Actuator Assembly

NOTE: Includes HY-32-A cartridge (shown below)  
NOTE: Maximum distance from button to valve is 20' (longer tubing required)  
NOTE: HY-30 84" longer tubing (0318094)

### HY-32-A ACTUATOR CARTRIDGE ASSEMBLY

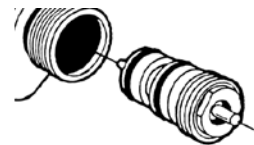

For use with HY-50-A and HY-71-A actuator assemblies

### HY-100-A (0318117) FIXTURE WALL METAL PUSH BUTTON

Item No.	Code No.	Part No.	Description
1.	<b>0318117</b>	HY-100-A	Fixture Wall Metal Button Assembly
2.	<b>0318006</b>	HY-111-A	Metal Button Kit
3.	<b>0305134</b>	EL-109	Spring
4.	<b>0318078</b>	HY-50-A	Actuator Assembly
5.	<b>0318028</b>	HY-29	Threaded Rod
6.	<b>0318109</b>	HY-105	Spacer
7.	<b>0318009</b>	HY-1002-A	Mounting Strap Kit

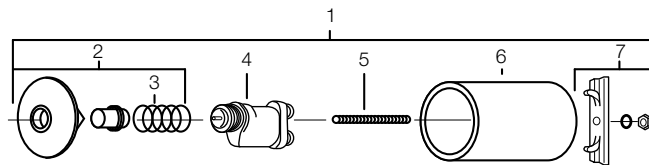

### HY-33-A (0318001) FIXTURE WALL PUSH BUTTON

1.	<b>0318001</b>	HY-33-A	Fixture Wall Push Button Assembly
2.	<b>0318007</b>	HY-1000-A	Push Button Kit
3.	<b>0318004</b>	HY-3	Spring
4.	<b>0318008</b>	HY-1001-A	Mounting Flange Kit
5.	<b>0318078</b>	HY-50-A	Actuator Assembly
6.	<b>0318028</b>	HY-29	Threaded Rod
7.	<b>0318109</b>	HY-105	Spacer
8.	<b>0318009</b>	HY-1002-A	Mounting Strap Kit

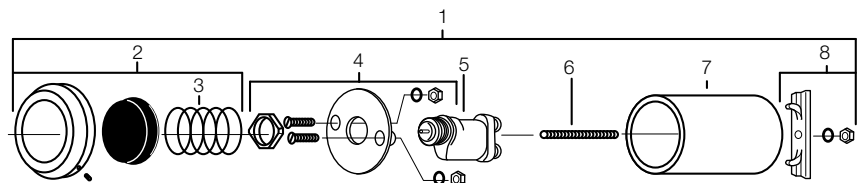

**Series 900® Flushometer**

**HY-113-A (0318120)  
METAL PUSH BUTTON PANEL MOUNT  
(MBPM VARIATION)**

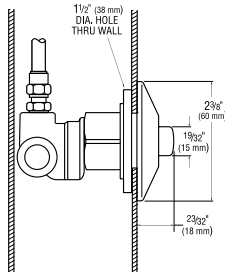

**HY-100-A (0318117)  
METAL PUSH BUTTON PANEL MOUNT  
(MBFW VARIATION)**

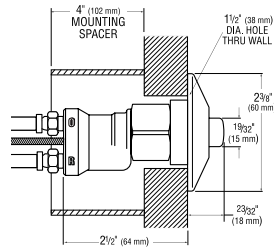

**HY-125-A (0318183)  
METAL PUSH BUTTON  
FIXTURE WALL (FW VARIATION)**

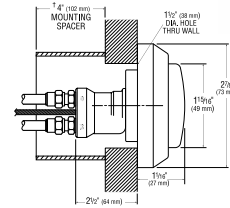

<sup>†</sup> Use Mounting Spacer only if wall thickness is less than 2" (50 mm).

Item			
No.	Code No.	Part No.	Description
1.	<b>0318115</b>	HY-86-A	Push Button Kit – includes Push Button, Flange, Spring & Set Screw
2.	<b>0305134</b>	EL-109	Spring
3.	<b>0318111</b>	HY-94-A	Mounting Flange Kit – includes Mounting Nut, Screws (2) & Tinnerman Nuts (2)
4.	<b>0318123</b>	HY-91-A	Flange

NOTE: Includes HY-32-A cartridge (0318031)  
NOTE: Maximum distance from button to valve is 20'  
(longer tubing required)  
NOTE: HY-30 84" longer tubing (0318094)

Item			
No.	Code No.	Part No.	Description
1.	<b>3318115</b>	HY-86-A	Push Button Kit – includes Push Button, Flange, Spring & Set Screw
2.	<b>0318109</b>	HY-105	Spacer Mounting Tube
3.	<b>0318125</b>	HY-95-A	Mounting Flange Kit – includes Mounting Flange, Mounting Nut, Screws (2), Nuts (2) & Washers (2)
4.	<b>0318123</b>	HY-4-A	RB Actuator Assembly
5.	<b>0318019</b>	HY-20-A	Inner Bushing
6.	<b>0305173</b>	HY-4	RB Body Hyd Actuator

NOTE: Includes HY-32-A cartridge (0318031)  
NOTE: Maximum distance from button to valve is 20'  
(longer tubing required)  
NOTE: HY-30 84" longer tubing (0318094)

Item			
No.	Code No.	Part No.	Description
1.	<b>0318002</b>	HY-1	CP Button Flange
2.	<b>0318111</b>	HY-105	Spacer Mounting Tube
3.	<b>0318003</b>	HY-2	RB Mounting Nut
4.	<b>0318067</b>	HY-123-A	Push Button Assembly
5.	<b>0318078</b>	HY-50-A	Actuator Assembly

NOTE: Includes HY-32-A cartridge (shown below)  
NOTE: Maximum distance from button to valve is 20'  
(longer tubing required)  
NOTE: HY-30 84" longer tubing (0318094)

**HY-79-A (0318081)  
METAL PARTITION PUSH BUTTON**

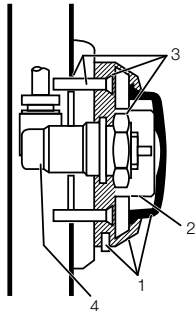

Item			
No.	Code No.	Part No.	Description
1.	<b>0318002</b>	HY-1-A	Push Button Kit – includes Push Button, Flange, Spring & Set Screw
2.	<b>0318004</b>	HY-3	Spring
3.	<b>0318003</b>	HY-2-A	Mounting Flange Kit – includes Mounting Flange, Mounting Nut, Screws (2) & Tinnerman Nuts (2)
4.	<b>0318123</b>	HY-71-A	Actuator Assembly

NOTE: Includes HY-32-A cartridge (shown at right)  
NOTE: Maximum distance from button to valve is 20'  
(longer tubing required)

## Series 900® Flushometer

### TROUBLESHOOTING GUIDE

#### 1. Push button leaks.

The actuator cartridge has an accumulation of lime or its seals are damaged or worn. Replace with a new HY-32-A cartridge.

#### 2. The flushometer DOES NOT flush and a small amount of leakage is visible below the valve.

- A. Foreign material lodged in the cartridge. Remove the cartridge and inspect for foreign material. Clean under running water.
- B. The actuator cartridge has an accumulation of lime or its seals are damaged or worn. Replace with a new HY-32-A cartridge.
- C. Plastic tubing is installed incorrectly. Install plastic tubing correctly.

#### ACTUATOR CARTRIDGE REMOVAL

##### Plastic Push Button Actuator Removal:

- (1) Loosen the setscrew in the button flange and remove the button, flange, and spring from the actuator body.
- (2) Unscrew the cartridge from the actuator body.

##### Metal Push Button Actuator Removal:

- (1) Remove the button or actuator assembly from the wall or fixture.
- (2) Disassemble the flange or button assembly from the actuator body.
- (3) Unscrew the cartridge from the actuator body.

**NOTE: The metal push button is designed to be vandal-proof and must be removed from the wall or fixture for service.**

#### 3. The flushometer DOES NOT flush or flushes only once and will not flush a second time when the button is pushed.

- A. The plunger is lodged in the actuator cartridge or the plunger bypass hole is clogged. Remove actuator housing and cartridge from the flushometer. Clean under running water. If cartridge parts are worn, deteriorated or limed up and problem persists after cleaning, replace with a new HY-83-A cartridge.
- B. Plastic tubing is installed incorrectly. Install plastic tubing correctly (Blue tube/Blue fitting, Yellow tube/Yellow fitting).

#### REMOVAL OF THE ACTUATOR FROM THE FLUSHOMETER:

Turn off water at the control stop. Unscrew the actuator housing coupling nut from the flushometer. Remove the actuator housing from the flushometer. The tubing connections can be left intact. Carefully remove the actuator cartridge from the flushometer body to prevent the actuator from abrupt separation due to expansion of an internal spring. If the actuator cartridge is lodged in the flushometer body cavity, gently grip the exposed portion of the cartridge with a channel-lock pliers and rotate back and forth to loosen the o-ring seal. Carefully separate the actuator housing to reveal the spring and plunger.

#### 4. Flushometer DOES NOT function (no flush).

- A. Control stop or main valve is closed. Open control stop or main valve.
- B. Relief valve is worn. Replace performance kit (Royal) or inside parts kit (Regal XL).

#### 5. Volume of water is not sufficient to siphon fixture.

- A. Control stop is not open wide enough. Adjust control stop for desired delivery of water volume.
- B. Urinal flushometer parts installed in a closet flushometer. Replace inside urinal flushometer parts with proper closet flushometer parts.
- C. Incorrect dual-filtered diaphragm assembly (Royal) or inside parts kit (Regal XL) is installed in flushometer; for instance, urinal assembly inside a closet flushometer, or low consumption assembly inside a higher consumption fixture. Determine the flush volume required by the fixture and replace Royal performance kit or inside parts kit. Use valve label and markings on fixture for reference.
- D. Water supply volume or pressure is inadequate. If no gauges are available to properly measure supply pressure or volume of water at the flushometer, then remove the relief valve from the dual-filtered diaphragm assembly (Royal) or inside parts kit (Regal XL), reassemble the flushometer and completely open the control stop. If the fixture siphons, more water volume is required.

**For Royal** — Install a higher flushing volume Royal Performance Kit.

**For Regal XL** — If a 3.5 gpf Inside Parts Kit is installed in the flushometer, then first flip the refill head (under the diaphragm) to obtain a 4.5 gpf volume. If this volume is still inadequate, remove the flow ring from the guide to obtain a 6.5 gpf Kit. If additional flow is still required, try a low pressure guide kit A-175-A (0301104).

#### IMPORTANT — LAWS AND REGULATIONS REQUIRING PROHIBIT THE USE OF HIGHER FLUSHING VOLUMES THAN LISTED ON FIXTURE OR FLUSHOMETER.

If the fixture does not siphon or if a low consumption flush is required, steps must be taken to increase the water supply pressure and/or volume. Contact the fixture manufacturer for minimum water supply requirements of the fixture.

#### 6. Flushometer closes off immediately.

- A. Ruptured or damaged diaphragm. Replace Royal performance kit (Royal) or inside parts kit (Regal XL).
- B. **For Regal XL** — An enlarged bypass orifice from corrosion or damage. Replace inside parts kit.
- 7. Length of flush is too short (Short Flush).
- A. **For Regal XL** — The diaphragm assembly and guide assembly are not hand tight. Screw the two assemblies hand tight.
- B. **For Regal XL** — An enlarged bypass orifice from corrosion or damage. Replace inside parts kit.
- C. Dual-filtered diaphragm assembly (Royal) or inside parts kit (Regal XL) is damaged. Replace Royal performance kit or inside parts kit.
- D. Incorrect dual-filtered diaphragm assembly (Royal) or inside parts kit (Regal XL) is installed in flushometer; for instance, urinal assembly inside a closet flushometer, or low consumption assembly inside a higher consumption fixture. Determine the flush volume required by the fixture and replace Royal performance kit or inside parts kit. Use valve label and markings on fixture for reference.

---

**Series 900® Flushometer**

---

---

**TROUBLESHOOTING GUIDE (CONTINUED)**

---

**7. Length of flush is too long (long flush) or continuous.**

- A. **For Royal** — Metering bypass hole in diaphragm is clogged. Remove the dual-filtered diaphragm assembly. Remove the primary and secondary filter rings from the diaphragm and wash under running water. Replace Royal performance kit if cleaning does not correct the problem.
- B. **For Regal XL** — Relief valve (A-19-A) is not seating properly or bypass orifice is clogged. Disassemble the working parts and wash thoroughly.

**NOTE: SIZE OF THE ORIFICE IN THE BYPASS IS OF UTMOST IMPORTANCE FOR THE PROPER METERING OF WATER INTO THE UPPER CHAMBER OF THE FLUSHOMETER. DO NOT ENLARGE OR DAMAGE THIS ORIFICE. REPLACE INSIDE PARTS KIT IF CLEANING DOES NOT CORRECT PROBLEM.**

- C. Supply line water pressure has dropped and is not sufficient to close the valve. Close control stop until pressure is restored.
- D. Dual-filtered diaphragm assembly (Royal) or inside parts kit (Regal XL) is damaged. Replace Royal performance kit or inside parts kit.
- E. Incorrect dual-filtered diaphragm assembly (Royal) or inside parts kit (Regal XL) is installed in flushometer; for instance, urinal assembly inside a closet flushometer, or low consumption assembly inside a higher consumption fixture. Determine the flush volume required by the fixture and replace Royal performance kit or inside parts kit. Use valve label and markings on fixture for reference.
- F. White closet relief valve has been used in a urinal flushometer. Replace closet relief valve (A-19-AC) with black urinal relief valve (A-19-AU).
- G. Inside cover is cracked or damaged. Replace the inside cover (A-71).
- H. Conditions in the piping system may contribute to the noise. A degree of high pressure in the piping may be relieved by adjustments to control stop. Other noises created by loose pipes, lack of air chambers, inadequate pipe sizes, etc., are problems that must be discussed with the building engineer.

**8. Chattering noise is heard during flush.**

- A. Inside cover is damaged. Replace inside cover (A-71).
- B. **For Regal XL** — A-156-A segment diaphragm has been installed upside-down. Reposition the segment diaphragm properly (see markings on the diaphragm).

---

**CARE AND CLEANING INSTRUCTIONS**

---

**DO NOT USE** abrasive or chemical cleaners (including chlorine bleach) to clean flushometers that may dull the luster and attack the chrome or special decorative finishes. Use **ONLY** mild soap and water, then wipe dry with a clean towel or cloth.

While cleaning the bathroom tile, protect the flushometer from any splattering of cleaner. Acids and cleaning fluids will discolor or remove chrome plating.

**When assistance is required, please contact Sloan Technical Support at: 1-888-SLOAN-14 (1-888-756-2614).**