



SERVICE PARTS LIST

BULLETIN NO.
54-07-3525

SPECIFY CATALOG NO. AND SERIAL NO. WHEN ORDERING PARTS		REVISED BULLETIN	DATE
M12™ Cross and Point Laser			Jan. 2022
CATALOG NO.	3622-20	STARTING SERIAL NO.	L42A
			WIRING INSTRUCTION

Service needs pertaining to accuracy or calibration can only be performed at Milwaukee Authorized Repair Centers:
MILWAUKEE ELECTRIC TOOL central repair 1401 Sycamore Ave. Greenwood, MS 38930-7277
 OR
 Via e-Service at: www.milwaukeetool.com/e-service. Questions, please call 1.800.SAWDUST
 OR
 Return it to a **MILWAUKEE FACTORY SERVICE CENTER** location, freight prepaid and insured.
 A copy of the proof of purchase should be included with the return product."

EXAMPLE:
 00

0

 Component Parts (Small #)
 Are Included When Ordering
 The Assembly (Large #).

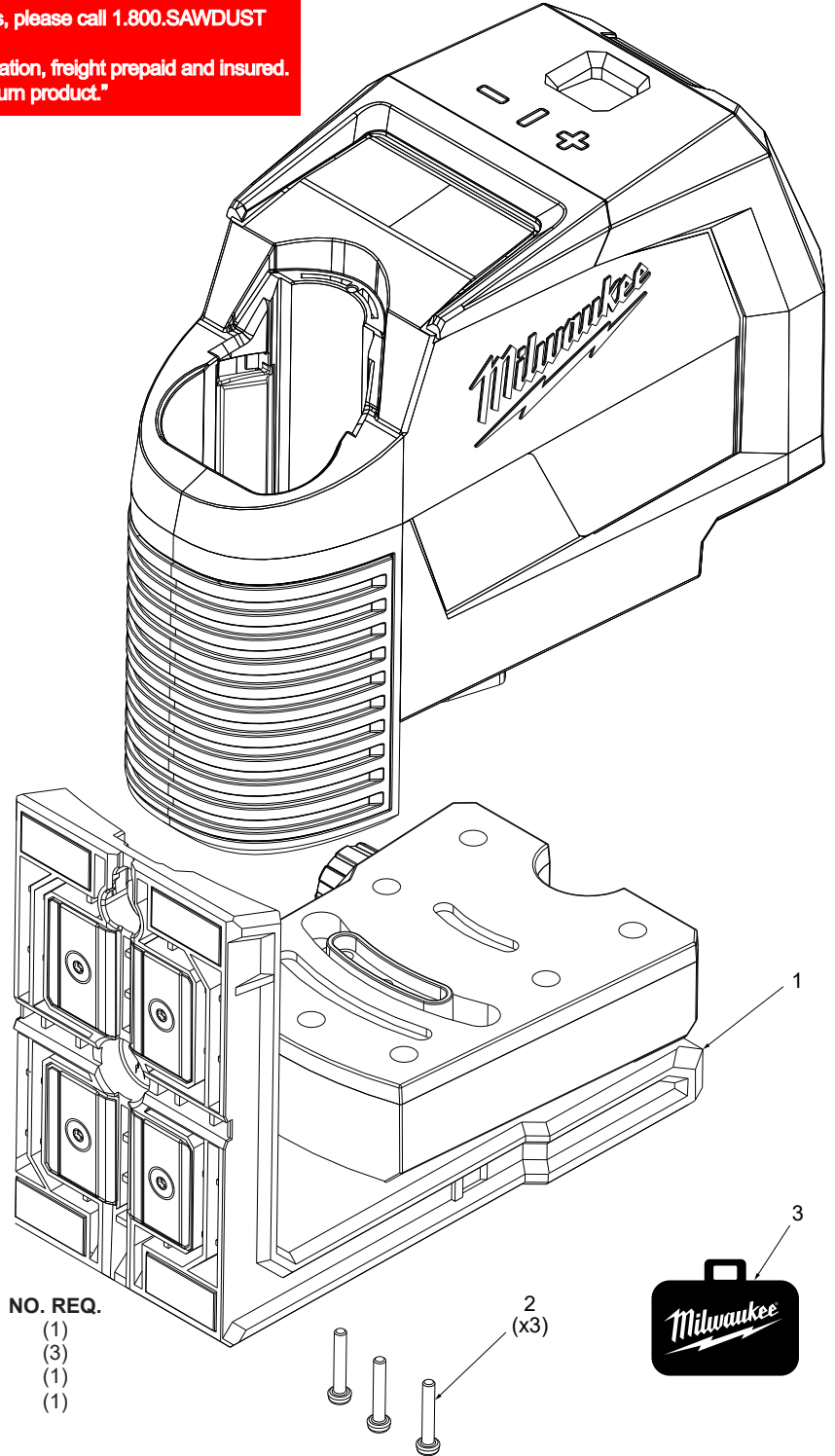

FIG.	PART NO.	DESCRIPTION OF PART	NO. REQ.
1	31-10-0035	Mount Assembly	(1)
2	-----	M2.5 x 16.8mm PH ST T8 Screw	(3)
3	42-55-0207	BMC	(1)
4	12-20-3622	Service Nameplate (Not Shown)	(1)

FIG. 4 NOTES
 4 A clean, dry surface is essential for proper performance for any adhesive system. The area intended for application of any adhesive label or nameplate must be prepared by cleaning with isopropyl alcohol. The solvent is to be applied with a clean, lint free applicator and the surface allowed to dry before applying the label or nameplate.