



INSTALLATION DATA

720 SERIES

DUAL VALVE GAS HEATING CONTROLS

The Robertshaw® 720 Series Gas Controls are designed for a wide variety of heating applications and can be used to replace most dual (six function) valves. They are available only in a 24 volt model used with a constant pilot. Models are available with and without a pressure regulator. Uni-Kits® are factory set at 3.5" W.C. for natural gas, but can be converted to L.P. by installing the regulator conversion kit included. (See Regulator Conversion section.)

The 720 Series, used with a constant pilot, is a six function valve incorporating a manual valve, safety shutoff magnet, dual automatic valves (hence the term "dual valves"), main gas regulator, and pilot adjustment. It features an integral manual selector used to select from four gas flow positions - off, on, pilot and "set." The "set" position provides pilot only gas flow during magnet energizing and lock up. Built-in stops serve to prevent accidental setting to the "off" position.

Wiring connections, manual selector and adjustments are easily accessible on the top of the valve. With a 3-9/16" swing radius, the 720 Series lends itself well to replacing many OEM valves. Controls are multiposition and can be mounted in any position (except upside down).

To prevent unsafe attempts at repair, special screws are used and replacement parts are NOT available.

SPECIFICATIONS

Electrical Ratings..... 24V AC, .5 amps
 Pressure Regulator
 Natural Gas.....factory set at 3.5" W.C.
 L.P. Gas factory set at 11.0" W.C.
 Pilot Outlet 1/4" tubing
 Ambient Temperature -40° to 175°F
 Maximum Inlet Pressure 7" W.C. - natural gas

REGULATION CAPACITIES (BTU'S)

SIZE	TYPE GAS			
	NATURAL		L.P.	
	MIN.	MAX.	MIN.	MAX.
3/8" x 3/8"	15,000	175,000	15,000	280,000
1/2" x 3/8"	15,000	175,000	15,000	280,000
1/2" x 1/2"	15,000	200,000	15,000	300,000
1/2" x 3/4"	15,000	200,000	15,000	300,000
3/4" x 3/4"	15,000	200,000	15,000	300,000

INSTALLATION INSTRUCTIONS

Turn off gas supply and electrical power to equipment before servicing.

PIPING

1. Check replacement valve for multiple outlets (side outlets). If it has them, be sure all unused outlets are plugged using the socket plugs provided.
2. Pipe or tubing must be clean and free of scale and dirt.
3. Make sure gas piping is pressure tested before control is connected. High pressure can damage control causing a hazardous condition. Do not subject control to more than 1/2 PSI, (14" W.C.) inlet pressure.
4. If it is not already installed, a drip leg (sediment trap) must be added to the gas supply line to the control. (See figure to the right). All piping must comply with local codes and ordinances and with National Fuel Gas Code (ANSI Z223.1/ NFPA, No. 54).

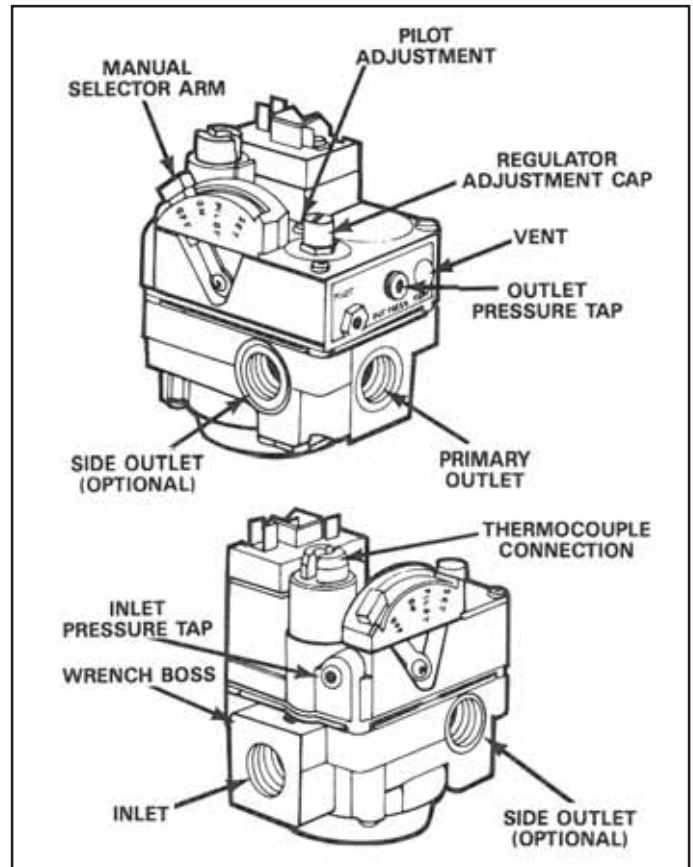

CAUTION

THIS DEVICE SHOULD BE INSTALLED BY A QUALIFIED TECHNICIAN WITH DUE REGARD FOR SAFETY AS IMPROPER INSTALLATION COULD RESULT IN A HAZARDOUS CONDITION.

5. Using pipe thread compound suitable for the gas being used, apply a small amount on the male pipe threads. (Do not use Teflon tape or Teflon compound.) Leave the first two threads clean. Never use compound on female threads as it might be pushed into the control body.
6. The gas valve is multiposition and can be mounted in any position (except upside down) without affecting its operation.
7. Install gas valve so gas flow conforms with the inlet and outlet of the control.

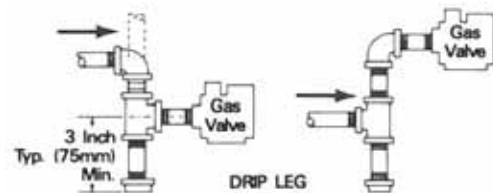

8. **DO NOT** insert any object other than suitable pipe or tubing in the inlet or outlet of this control. Internal damage may occur and result in a hazardous condition. A backup wrench should only be used on the wrench boss provided for this purpose (see drawing), never on body of the control, as this could distort the casting. **NOTE:** Do not overtighten any pipe connections, as this could crack the valve body. A valve with a cracked valve body will not be warrantied.

INSTALLATION INSTRUCTIONS (Cont'd)

PILOT TUBING

1. Make sure tubing is free of burrs and dirt.
2. We strongly recommend that the pilot orifice be checked and cleaned if necessary at this time.
3. Connect pilot tubing into the control using fitting provided, and tighten for a gas-tight seal.

PRESSURE REGULATOR VENT

The 720 Series when equipped with a pressure regulator, has a standard equipment built-in Vent Limiter. The regulator vent is tapped 1/8" tubing if vent tubing is required. **CAUTION:** If bleed tubing is used, do not allow main burner or pilot flame impingement on the tubing as this will eventually cause clogging of the tubing and improper regulator operation. If bleed tubing is not used, the regulator vent must be properly shielded from moisture.

THERMOCOUPLE CONNECTION

The thermocouple nut should be started and turned all the way in by hand. An additional quarter turn with a small (4") wrench will then be sufficient to set the lock washer. **CAUTION:** Overtightening may cause damage to the thermocouple or magnet and is unnecessary.

Replacement magnets are not available. If magnet is bad, replace the valve.

WIRING

DO NOT short gas valve terminals. This will damage wall thermostat and void warranty.

1. Check the system for the proper transformer by comparing the VA ratings of the transformer and the system. The system rating is determined by multiplying the voltage draw times the amp draw. Normally 20VA transformers are sufficient for heating only applications and 40VA for heating/cooling applications.
2. Connect lead from transformer to #1 terminal on the gas valve (see drawing.)
3. Connect lead to wall thermostat to #2 terminal on gas valve (see drawing).

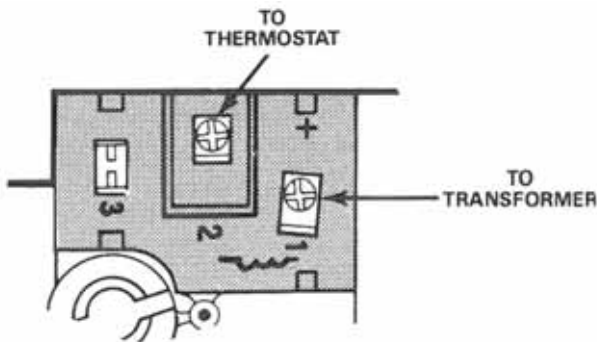

LEAK TEST

Leak test with a soap solution after installation with main burner on. Coat pipe and tubing joints, gasket, etc. with soap solution. Bubbles indicate leaks.

OPERATING INSTRUCTIONS



CAUTION

1. This appliance has a pilot burner which must be lit by hand. If the pilot flame has gone out, follow these instructions exactly.
WARNING: If you do not follow these instructions exactly, a fire or explosion may result in property damage, personal injury, or loss of life.
2. Smell all around the appliance area for gas. If the appliance uses LP (bottled) gas, be sure to smell next to the floor because LP gas is heavier than air.
WARNING: If you smell gas, immediately shut off the manual valve in the gas piping to the appliance. Don't touch any electrical switch or use the phone. Leave the building and call your gas supplier. If he cannot be reached, call the fire department.
3. **WARNING:** Do not force the gas control knob on the appliance. Use only your hand to push down and/or to turn the gas control knob. Never use any tools. If the gas control knob will not operate by hand, the control should be replaced by a qualified service technician. Force or attempted repair may result in fire or explosion.
4. **WARNING:** The gas control must be replaced if it has been exposed to water.

1. Turn wall thermostat to its lowest setting. Remove burner access panel(s).
Selector arm must only be operated by hand (see below). **DO NOT** use pliers, wrenches or other tools to operate the arm. The selector arm cannot be moved into the "off" position without first depressing the lever in the "on" position.
2. Move selector arm to the "off" position. (See figure 1.)
3. **WARNING:** Wait at least 5 minutes to allow any gas in the combustion chamber to vent. If you then smell gas in the appliance area or near the floor, STOP and follow warning instructions. Failure to do so may result in fire or explosion.
4. If you don't smell gas, hold match at pilot burner. **WARNING:** If pilot lights without moving selector arm to the "set" position, replace control. Push selector arm to the "set" position and hold it while lighting the pilot burner. (See figure 2.) Allow pilot to burn approximately 1 minute. If pilot does not remain lit after returning selector arm to "pilot" position, (see figure 3), repeat operation allowing longer period before releasing the selector arm. (Adjust pilot, if necessary, as noted under "Pilot Burner Adjustment".) The thermocouple may also be defective and should be checked (see Service Instructions.)
5. Move selector arm to the "on" position, (see figure 4), and set room thermostat to desired temperature. Allow burner to cycle on and off.
6. Replace burner access panel(s).

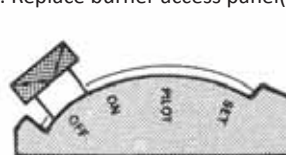

FIGURE 1

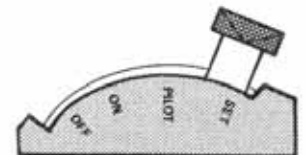

FIGURE 2

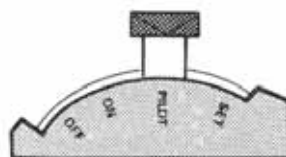

FIGURE 3

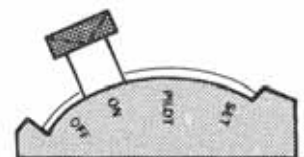

FIGURE 4

SERVICE INSTRUCTIONS

CAUTION: If control has been exposed to water in any way, it must be replaced. If gas valve fails to shut off, do not turn off electrical power. Turn off gas supply allowing fan or circulating pump (if so equipped) to continue running until system has cooled. Replace control.

AUTOMATIC PILOT SYSTEM

To perform the following test, we recommend using a reliable digital meter. There are three major causes of pilot outage in the automatic pilot systems.

1. Improper pilot operation.
2. Low output thermocouple or thermopile.
3. Inoperative automatic pilot magnet.

Test procedures and steps to follow in checking each component of the automatic pilot systems are listed below.

Thermocouple Check

A closed circuit millivolt check is used to check thermocouple output. This check is performed as follows:

1. Check for proper pilot operation.
2. Use a millivolt meter with a 0-50 millivolt range.
3. Connect Adaptor 10-038 and millivolt meter leads as shown in figure below. Be sure connections are snug.

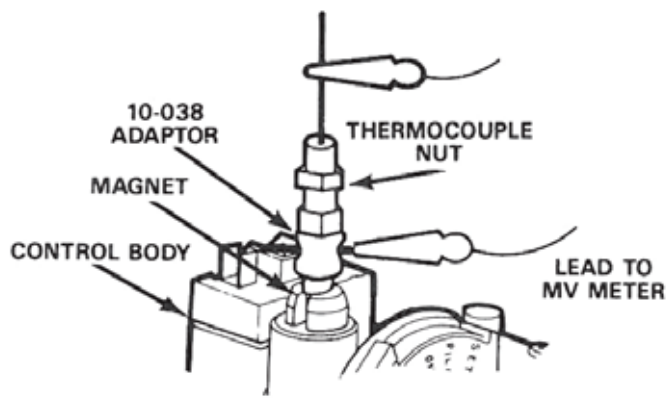

5. Check closed circuit thermocouple output. If less than eight millivolts, replace with Robertshaw 1970 or 1980 series thermocouple.
6. Repeat standard lighting procedure after thermocouple replacement.

Automatic Pilot Magnet Check (Thermocouple Type)

If the closed circuit check shows the thermocouple output is greater than eight millivolts and pilot will not remain lit when selector arm is released after initial lighting procedure, check operation of magnet as follows:

1. Adaptor 10-038 should remain connected in system as shown in figure above.
2. Follow standard lighting procedure and continue holding selector arm in the "set" position.
3. Allow thermocouple output to stabilize and note meter reading.
4. Extinguish pilot by moving selector arm to "off" position.
5. A good magnet should remain locked up for a drop of five millivolts or more from the original stabilized reading before releasing.
6. If magnet does not operate properly, replace the valve.

PILOT BURNER ADJUSTMENT

1. Adjust pilot key to provide properly sized flame on the thermocouple. The flame should cover the upper 3/8" of the tip.

PRESSURE REGULATOR ADJUSTMENTS

Adjustment of the pressure regulator is not normally necessary since it is preset at the factory. However, field adjustment may be accomplished as follows:

NOTE: Manometer attachment may be accomplished at pressure tap plug, above control outlet, as shown in figure below. If using inlet pressure tap to measure incoming pressure see drawing on first page.

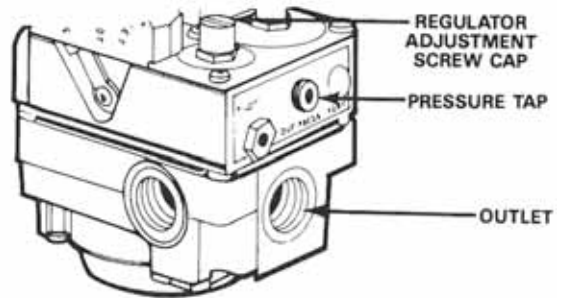

1. Manometer or gauge attachment may be accomplished at pressure tap plug.
2. Remove regulator adjustment screw cap. (Top of control.)
3. With small screwdriver, rotate adjustment screw clockwise to increase, or counterclockwise to decrease pressure to comply with manufacturer's specifications.
4. Replace regulator adjustment screw cap.

REGULATOR CONVERSION

CAUTION: Main burner and pilot orifices must be changed when regulator is converted from one type gas to another.

The 720 Series valves can be converted from natural to L.P. by installing the enclosed conversion kit.

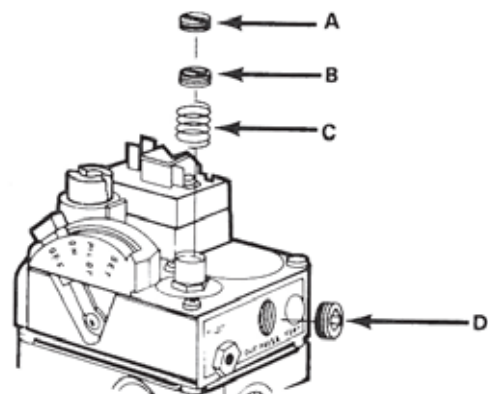

WARNING

Servicing of gas controls, appliances and systems must be performed by qualified service personnel only.

1. Turn off gas and electricity to appliance.
2. Remove slotted cap (A), adjusting screw (B), and natural gas spring - not color coded - (C), from control.
3. Install new L.P. spring - color coded with a black strip.
4. Install new adjusting screw (B).
5. Attach manometer or pressure gauge at the outlet pressure tap.
6. Turn gas and electricity on.
7. Turn room thermostat to call for heat.
8. With burner on, adjust screw (B) to supply L.P. gas to pressure as recommended by the appliance manufacturer.

SERVICE INSTRUCTIONS (Cont'd)

9. If adjusting screw (B) reaches its maximum depth (bottoms out) before recommended pressure setting is reached, turn screw counterclockwise until pressure drops slightly (approximately 0.1" W.C.) **WARNING:** Do not stretch or alter spring.
10. Turn off gas and electricity to appliance.
11. Remove manometer or pressure gauge and reinstall fitting.
12. Install new red slotted cap in place of (A).
13. Turn gas and electricity on.
14. With burner operating, immediately check all fittings for leaks with soap solution. Bubbles indicate leaks that must be corrected.
15. Attach label to show control has been converted to L.P.
16. Set room thermostat to desired temperature.



Customer Service Telephone 1.800.304.6563
Customer Service Facsimile 1.800.426.0804
HVACCustomerService@robertshaw.com

For Technical Service
Telephone 1.800.445.8299
Facsimile 1.630.260.7294
TechnicalService@robertshaw.com

Robertshaw®, Ranco®, Paragon® and Uni-Line® are trademarks of Robertshaw, its subsidiaries and/or affiliated companies. All other brands mentioned may be the trademarks of their respective owners.

www.uni-line.com
www.robertshaw.com
©2014 Robertshaw
08/14 -1-489 RevB