

CODE NUMBER

33820006

DESCRIPTION

Filtered, Refrigerated, 304 Stainless Steel, DropSpot™ On-wall Bottle Filler with Bi-level Cooler.

DETAILS

- Mounting: On-wall
- Configuration: Bottle Filler with Bi-level Cooler
- Filter Option: Filtered (FIL)
- Refrigeration Option: Refrigerated (REF)
- Finish: 304 Stainless Steel (SS)
- Chilling Capacity: 8.0 gph (30.3 Lph)
- Full Load Amps: 5.3
- Length: 19" (483mm)
- Width: 38" (965mm)
- Height: 39 3/5" (1,006mm)
- Weight: 112 lbs
- Installation Location: Indoor
- Number of Stations Served: 2
- Bottle Filler Water Flow Rate: Up to 1.2 gpm
- Bubbler Water Flow Rate: 0.3 gpm (1.1 Lpm)

POWER

- (Standard) 115VAC, 60Hz, 5.3A
- Provide Duplex Receptacle on GFCI Protected Circuit

FEATURES
Bottle Filler

- Touch-free sensor operated bottle filler with 20 second max run time
- ADA compliant when installed properly
- Up to 1.2 gpm fill rate for quick fill
- Laminar flow water supply
- Soft ambient white light to indicate filter status
- Backlit LED light illuminates bottle filling area when sensor is activated
- Bottle Counter Display indicates the number of 16 oz plastic bottles saved from a land fill as well as the ounces of water dispensed for water consumption tracking

Electric Water Cooler

- ADA compliant when installed properly
- Rough-in matches other manufacturers' for easy replacement
- Antimicrobial bubbler, push bar, and other components
- Drop-down door assembly provides easy access to filter
- Patent pending push bar designed to be activated at any touch point and to provide easy access for cartridge replacement
- Chilling capacity of 8.0 gph of 50F drinking water, based on 80F inlet water and 90F ambient
- Versatile mounting style that allows for left high or right high

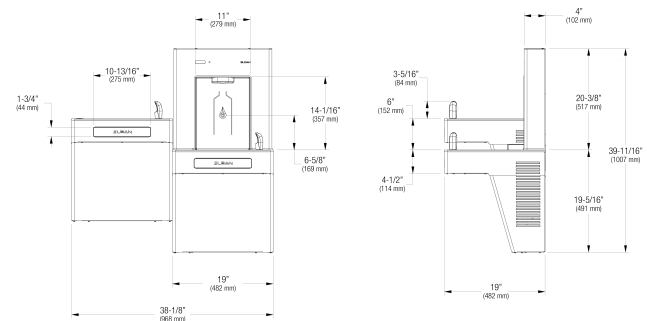
Filter

COMPLIANCES & CERTIFICATIONS

(ADA Compliant, cUPC Certified, cULus Certified, cUPC Low Lead Compliant, TAS)

ADDITIONAL COMPLIANCES

Listed to UL 399/CSA C22.2 No.120/IAPMO has listed this product to ASME A 112.18.1 / CSA B45.4, IGC 226, IGC 115, NSF-372 and NSF-61/Meets emissions requirement for the FCC/Meets Canada OBC, QBC, and other accessibility requirements/Filter listed to NSF-42, NSF-53, NSF-401

RECOMMENDED SPECIFICATION

Sloan's DropSpot™ On-wall Bottle Filler with Bi-level Cooler Filtered Refrigerated Stainless. Chilling capacity of 8.0 gph of 50F drinking water, based on 80F inlet water and 90F ambient. Unit shall be activated from an antimicrobial front pushbar using less than 5 pounds of force. Bubbler shall deliver a 0.3 gpm flow. Basin and cabinet shall be constructed from 304 stainless steel with satin finish. Bottle filler shall include sensor operated activation with a 20 second maximum run time. Bottle counter display indicates the number of 16 oz plastic bottles saved as well as the ounces of water dispensed for water consumption tracking. White light indicates the water filter status. Unit shall include LED lights that illuminate the bottle filling area. Bottle filler housing construction shall be stainless steel. Bottle filler shall provide up to 1.2 gpm flow rate with a laminar flow. Push bar shall be activated by any touch point on the bar and shall be opened by Sloan access

Sloan 10500 Seymour Ave, Franklin Park, IL 60131

 Phone: 800.982.5839 • Fax: 800.447.8329 • sloan.com

- 3000 gallon
- Effectively reduces PFOA, PFOS, lead, microplastic, cyst, particulate class 1, chlorine, and odor
- Certified to comply with NSF-42, NSF-53, and NSF-401 standards
- Prop 65 compliant

NOTES

All information contained within this document subject to change without notice.

ROUGH-IN

key. Filter drop-down assembly shall be opened by Sloan access key. Filter used in the unit shall have capacity of 3000 gallons at a minimum, and shall reduce PFOA, PFOS, lead, microplastic, cyst, chlorine and class 1 particles.

DOWNLOADS

- [Additional Downloads](#)

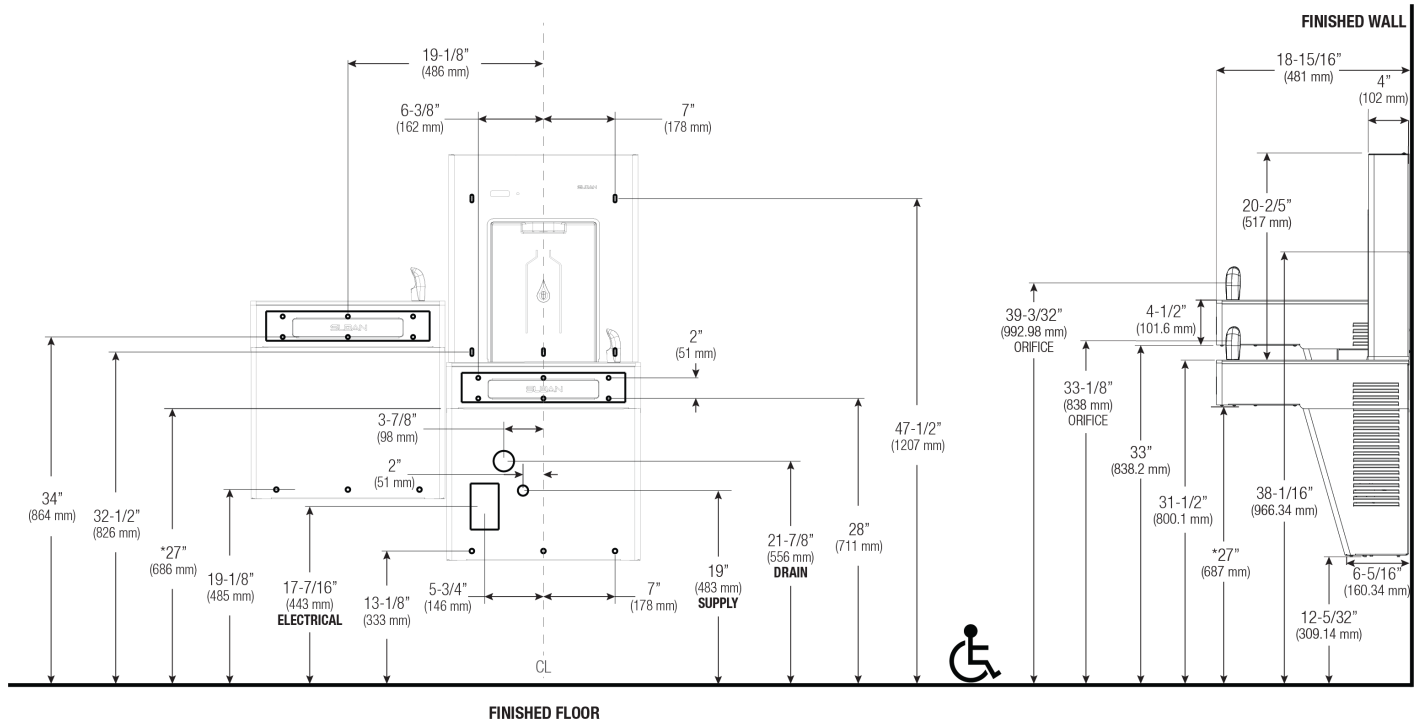

Sloan 10500 Seymour Ave, Franklin Park, IL 60131

Phone: 800.982.5839 • Fax: 800.447.8329 • sloan.com