

**CODE NUMBER**

33820027

**DESCRIPTION**

Unfiltered, Refrigerated, Black, DropSpot™ On-wall Bottle Filler with Bi-level Cooler.

**DETAILS**

- Mounting: On-wall
- Configuration: Bottle Filler with Bi-level Cooler
- Filter Option: Unfiltered (UNFIL)
- Refrigeration Option: Refrigerated (REF)
- Finish: Black (BLK)
- Chilling Capacity: 8.0 gph (30.3 Lph)
- Full Load Amps: 5.3
- Length: 19" (483mm)
- Width: 38" (965mm)
- Height: 39 3/5" (1,006mm)
- Weight: 110 lbs
- Installation Location: Indoor
- Number of Stations Served: 2
- Bottle Filler Water Flow Rate: Up to 1.2 gpm
- Bubbler Water Flow Rate: 0.3 gpm (1.1 Lpm)

**POWER**

- (Standard) 115VAC, 60Hz, 5.3A
- Provide Duplex Receptacle on GFCI Protected Circuit

**FEATURES**
**Bottle Filler**

- Touch-free sensor operated bottle filler with 20 second max run time
- ADA compliant when installed properly
- Up to 1.2 gpm fill rate for quick fill
- Laminar flow water supply
- Soft ambient white light to indicate filter status
- Backlit LED light illuminates bottle filling area when sensor is activated
- Bottle Counter Display indicates the number of 16 oz plastic bottles saved from a land fill as well as the ounces of water dispensed for water consumption tracking

**Electric Water Cooler**

- ADA Compliant when installed properly
- Rough-in matches other manufacturers' for easy replacement
- Antimicrobial bubbler, push bar, and other components
- Drop-down door assembly provides easy access to filter
- Patent pending push bar designed to be activated at any touch point and to provide easy access for cartridge replacement
- Chilling capacity of 8.0 gph of 50F drinking water, based on 80F inlet water and 90F ambient
- Versatile mounting style that allows for left high or right high

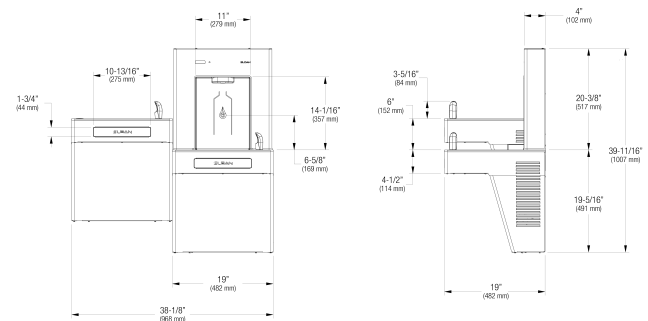
**COMPLIANCES & CERTIFICATIONS**

(ADA Compliant, cUPC Certified, cULus Certified, cUPC Low Lead Compliant, TAS)

**ADDITIONAL COMPLIANCES**

Listed to UL 399/CSA C22.2 No.120/IAPMO has listed this product to ASME A 112.18.1 / CSA B45.4, IGC 226, IGC 115, NSF-372 and NSF-61/Meets emissions requirement for the FCC/Meets Canada OBC, QBC, and other accessibility requirements

**RECOMMENDED SPECIFICATION**

Sloan's DropSpot™ On-wall Bottle Filler with Bi-level Cooler Unfiltered Refrigerated black powder coat. Chilling capacity of 8.0 gph of 50F drinking water, based on 80F inlet water and 90F ambient. Unit shall be activated from an antimicrobial front pushbar using less than 5 pounds of force. Bubbler shall deliver a 0.3 gpm flow. Basin and cabinet shall be constructed from galvanized steel with black powder coat finish. Bottle filler shall include sensor operated activation with a 20 second maximum run time. Bottle counter display indicates the number of 16 oz plastic bottles saved as well as the ounces of water dispensed for water consumption tracking. Unit shall include LED lights that illuminate the bottle filling area. Bottle filler housing construction shall be black galvanized steel. Bottle filler shall provide up to 1.2 gpm flow rate with a laminar flow. Push bar shall be activated by any touch point on the bar and shall be opened by Sloan access key.

**Sloan 10500 Seymour Ave, Franklin Park, IL 60131**

 Phone: 800.982.5839 • Fax: 800.447.8329 • [sloan.com](http://sloan.com)

**NOTES**

All information contained within this document subject to change without notice.

**DOWNLOADS**

- [Additional Downloads](#)

**ROUGH-IN**

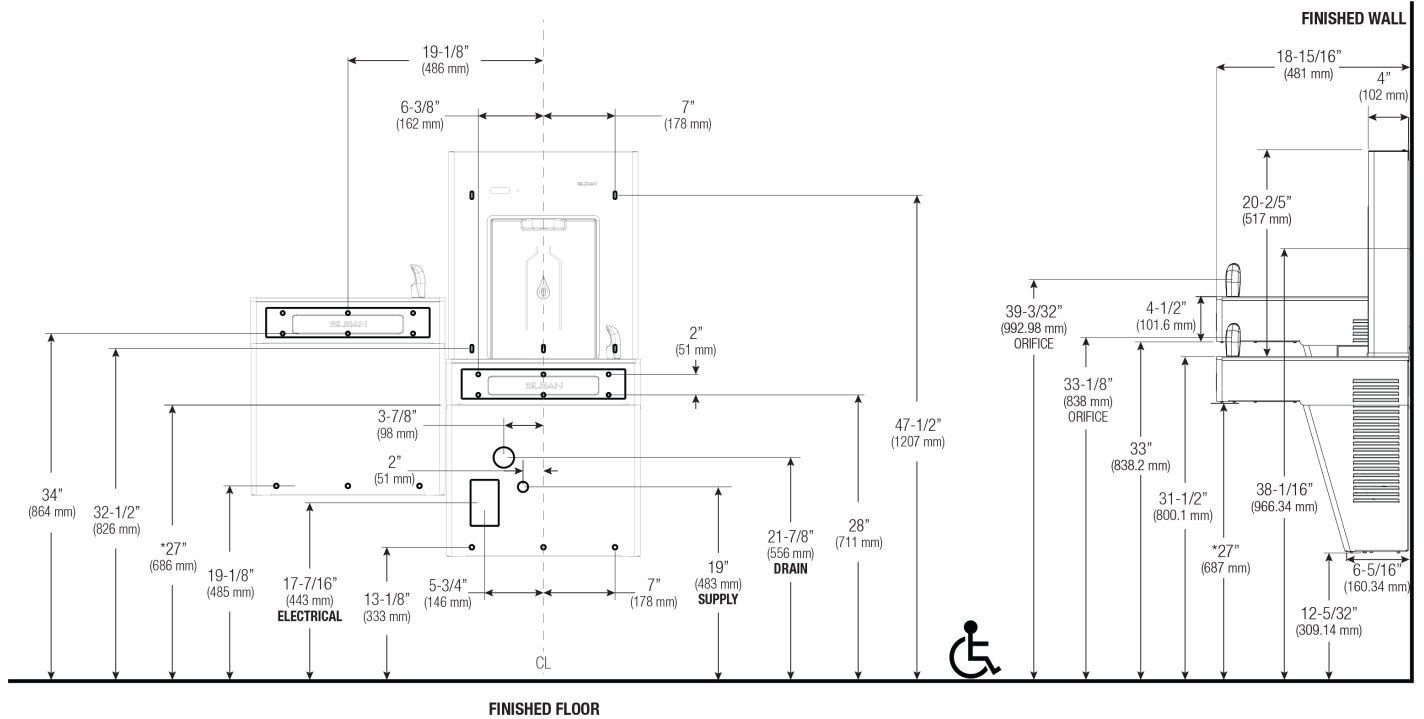

Sloan 10500 Seymour Ave, Franklin Park, IL 60131

Phone: 800.982.5839 • Fax: 800.447.8329 • [sloan.com](http://sloan.com)