

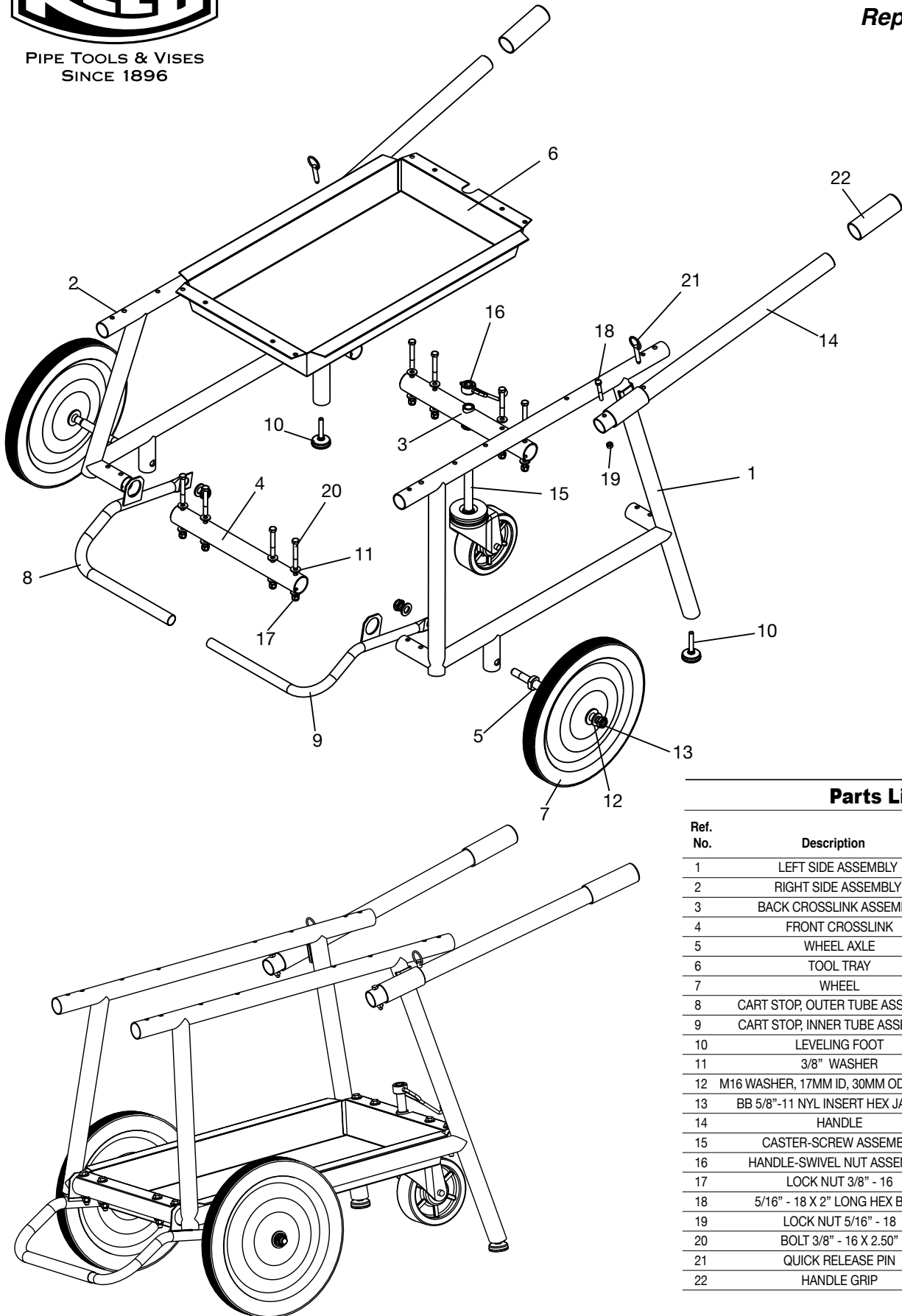

PIPE TOOLS & VISES  
SINCE 1896

# 5401CRT Machine Cart

## Replacement Parts



### Parts List

Ref. No.	Description	Item Code	Quantity
1	LEFT SIDE ASSEMBLY	96672	1
2	RIGHT SIDE ASSEMBLY	96671	1
3	BACK CROSSLINK ASSEMBLY	96673	1
4	FRONT CROSSLINK	96670	1
5	WHEEL AXLE	96677	2
6	TOOL TRAY	96680	1
7	WHEEL	46685	2
8	CART STOP, OUTER TUBE ASSEMBLY	96675	1
9	CART STOP, INNER TUBE ASSEMBLY	96676	1
10	LEVELING FOOT	46689	2
11	3/8" WASHER	30011	16
12	M16 WASHER, 17MM ID, 30MM OD, 3MMTHK	30250	4
13	BB 5/8"-11 NYL INSERT HEX JAM NUT	30111	4
14	HANDLE	96679	2
15	CASTER-SCREW ASSEMBLY	96681	1
16	HANDLE-SWIVEL NUT ASSEMBLY	96682	1
17	LOCK NUT 3/8" - 16	23366	8
18	5/16" - 18 X 2" LONG HEX BOLT	30248	2
19	LOCK NUT 5/16" - 18	30245	2
20	BOLT 3/8" - 16 X 2.50"	37321	8
21	QUICK RELEASE PIN	94477	2
22	HANDLE GRIP	34762	2

Reed Manufacturing Company  
1425 West 8th Street  
Erie, PA 16502 USA

**QUALITY**  
& Service  
that Last a Lifetime

Phone: 800-666-3691 or 814-452-3691  
Fax: 800-456-1697 or 814-455-1697  
www.reedmfgco.com

RP-1011-109